

**DuraMax™ 5400-Series Telescopic Sliding Door**  
**Installation Instructions**  
**Quick-Reference Guide**  
**204076**  
**Rev G, 02/10/2017**

**Prohibition on Copying**

Any unauthorized reproduction, disclosure or distribution of copies by any person of any portion of this work may be a violation of copyright law of the United States of America and other countries, could result in the awarding of statutory damages of up to \$250,000 (17 USC 504) for infringement, and may result in further civil and criminal penalties. All rights reserved.

**Quick-Reference Guide**

TABLE OF CONTENTS

1. PURPOSE ..... 3

2. PREREQUISITES ..... 3

3. INSTALLATION INSTRUCTIONS ..... 3

3.1 Unpacking the Door Components ..... 3

3.2 Preparing the Assembly for Installation ..... 4

3.3 Preparing for Doorway Holding Beam Installation ..... 4

3.4 Installing the Overhead Sensors ..... 5

3.5 Connecting the Holding Beams ..... 5

3.6 Installing the Header and Jamb Assembly ..... 5

3.7 Attaching the SO Panel to the Breakout Track ..... 8

3.8 Threshold Installation ..... 8

3.9 Installing the SO Panel ..... 9

3.10 Installing the Fast Panels ..... 10

3.11 Installing the Slow Panels ..... 10

3.12 Adjusting the Panels ..... 12

3.13 Installing the Panel Timing Assembly ..... 15

3.14 Installing Header Seal & Weatherstripping ..... 17

3.15 Adjusting the Bottom Sweeps ..... 17

3.16 Performing the Final Adjustments ..... 18

3.17 MC521 Pro Control Box Monitoring Setup ..... 19

3.18 Performing the Closeout Procedure ..... 19

3.19 Replacement Parts ..... 19

ATTACHMENTS

Attachment 1, Documents, Definitions, Special Tools, Equipment, Materials, and Consumables .....20

Attachment 2, Replacement Parts .....21

Attachment 3, Wiring Diagram .....28

Attachment 4, REPLACING GLASS DOOR PANELS .....29

Attachment 5, BOTTOM GUIDE INSTALLATION .....32

Attachment 6, Dura-Max 5400 Option: Installing Solenoid Locking .....33

Attachment 7, Dura-Max 5400 Option: Replacing a Solenoid Lock .....35

Attachment 8, Dura-Max 5400 Option: Installing a Panic bar with Access Control .....36

Attachment 9, Dura-Max 5400 Option: Adjusting the Solenoid Lock .....41

Attachment 10, Dura-Max 5400 Option: Adjusting the Pin catch for Access Control.....43

## 1. PURPOSE

### 1.1 Discussion

This manual provides installation instructions for the Stanley DuraMax 5400-series sliding door system. See Figure 1. For additional information refer to the following manuals as necessary:

- Stanley Access Technologies Manual No. 204066 “MC521 Pro Controller Installation and Operation Manual”

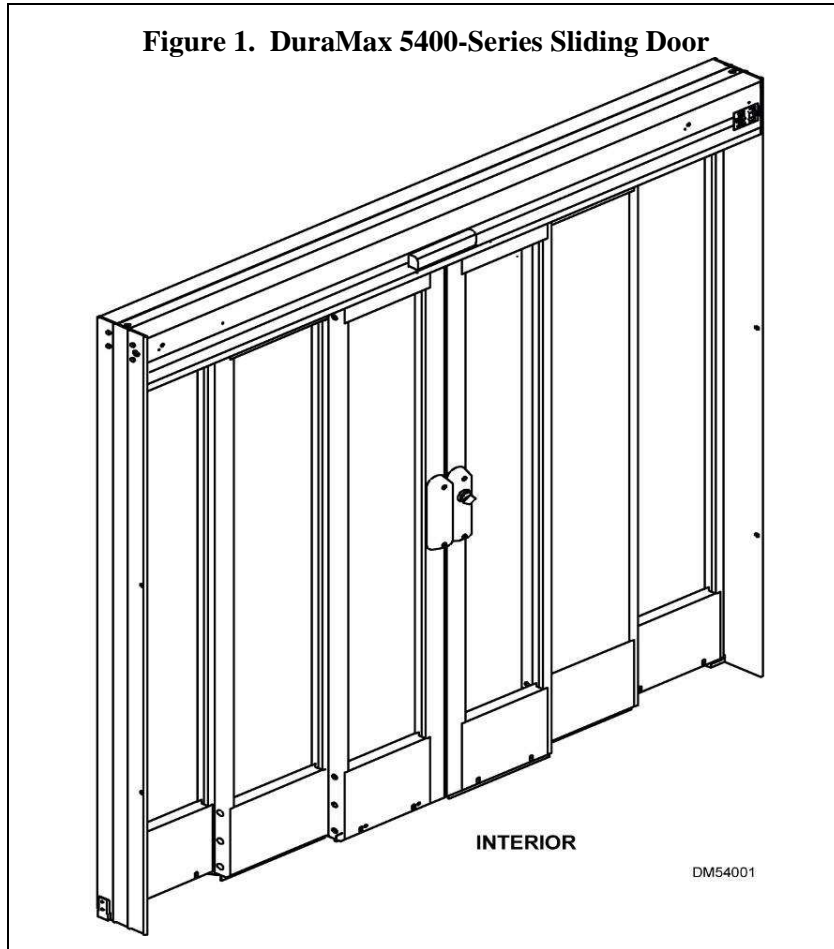

**NOTE:** Shown with ¼” jambs; ¾” jambs are standard

- Manufacturer Installation instructions for X-Zone ST Sensor

- Stanley Access Technologies Manual No. 203926 “Rotary/Key Switch Installation Instructions”

- Stanley Access Technologies Manual No. 203981 Jamb Camera System Installation Instructions”

### 1.2 Applicability

This manual is applicable to the Stanley DuraMax 5400-series door system. This manual does not cover retrofit of an existing door system.

## 2. PREREQUISITES

2.1 De-energize electrical power to the door before performing installation or maintenance.

2.2 Set up a protective barrier (caution/warning tape) to prevent unauthorized access to work area.

2.3 Clear the area of all obstructions.

2.4 Review all attachments.

2.5 Review the following critical installation processes:

- a. Ensure the header and jamb assembly is plumb and square.
- b. Ensure the top and bottom pivots are aligned.
- c. Ensure the drive pin is properly adjusted.
- d. Ensure the SX slow panel sweep is pulled down and provides proper interface with roller guide.

### 3. INSTALLATION INSTRUCTIONS

#### **NOTE:**

These instructions are intended to supplement the other installation instructions supplied with this package.

#### 3.1 Unpacking the Door Components

3.1.1 Refer to Figure 2, and UNPACK the components from the shipping container. Ensure the following major components are present:

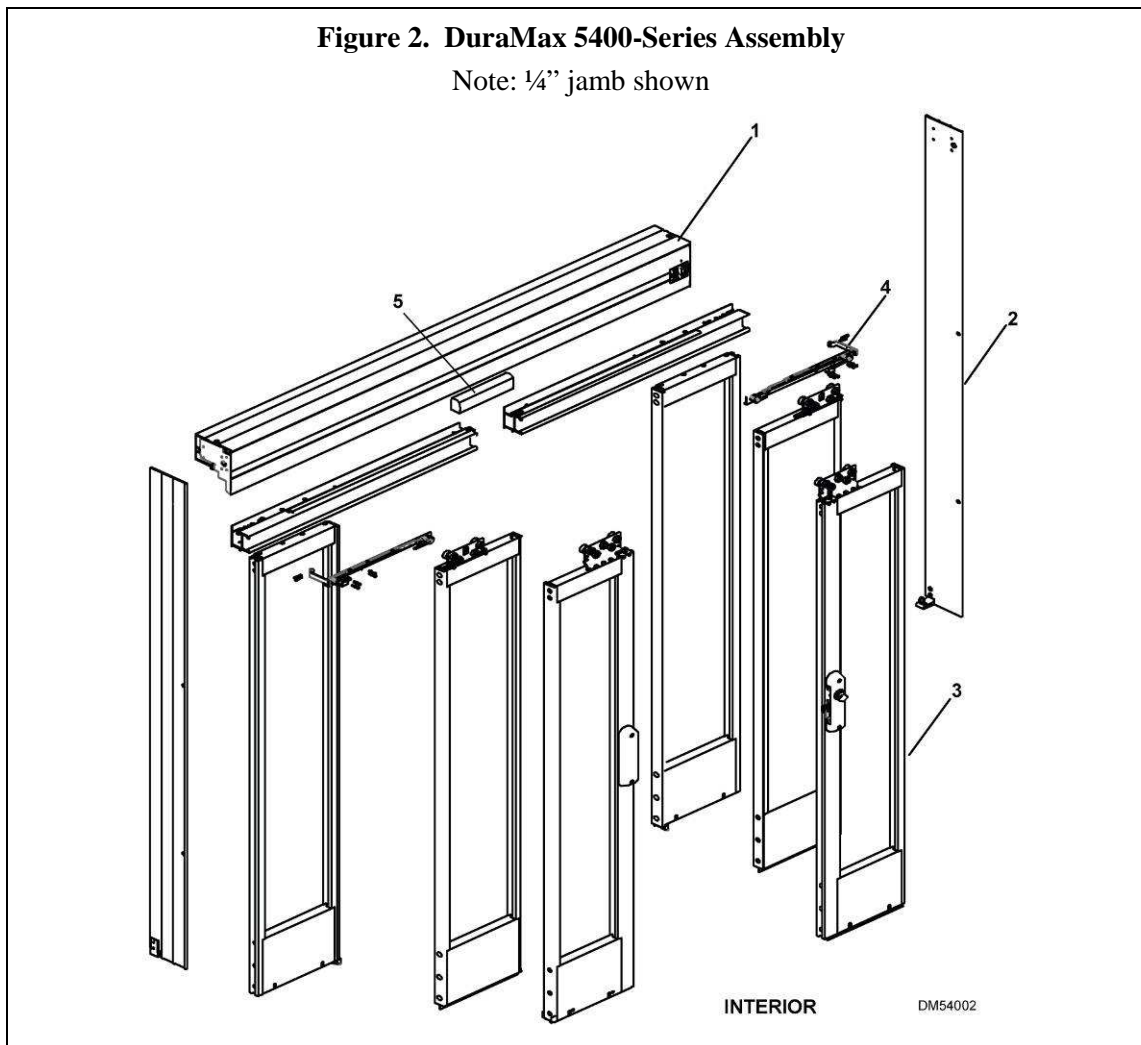

- |   |  |
|---|--|
| 1. Header assembly with breakout tracks | 5. Two overhead sensors                  |
| 2. Two jambs                            | 6. Doorway holding beams (not pictured)* |
| 3. Six panels                           | 7. Hardware kit (not pictured)           |
| 4. Two panel timing belt assemblies     |  |

\* **NOTE:** Holding beams are packed in header of doors with ¼" jambs, and factory installed in doors with 1 ¾" jambs.

### 3.2 Preparing the Assembly for Installation

- 3.2.1 With the header cover facing up, POSITION the header assembly onto saw horses. See Figure 3.

**Figure 3. Removing the Breakout Track**

HEADER, COVER FACING UP

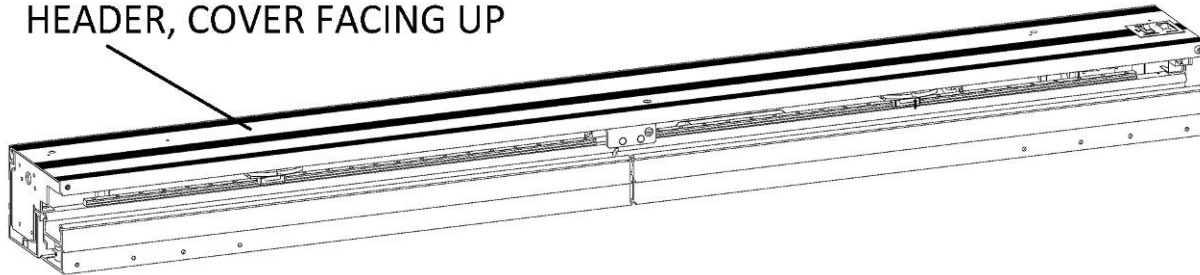

#### **CAUTION**

The breakout track assemblies are held in place by the ball detents. SECURE the lower header assembly BEFORE removing the breakout track assemblies to prevent it from inadvertently dropping downward.

- 3.2.2 Refer to Figure 3, and HOLD the lower header securely to prevent it from dropping downward.
- 3.2.3 PUSH the left breakout track downward and in the breakout direction.
- 3.2.4 REMOVE the left breakout track assembly from the header assembly.
- 3.2.5 REPEAT steps 3.2.2 through 3.2.4 for the right breakout track assembly.

### 3.3 Preparing for Doorway Holding Beam Installation

#### **3.3.1 For 1/4" jambs only:**

**NOTE** The jamb is temporarily installed in the opening to determine holding beam hole locations.

- Refer to Figure 4 (next page), and with the jamb pivot positioned toward the building *exterior*, temporarily INSTALL the side jamb into the door opening.
- Using the jambs as a guide, MARK the two doorway holding beam hole locations.
- REMOVE the jambs from the door opening.
- Using a  $3/4$ " drill bit, DRILL a 1" deep doorway holding beam hole into jamb wall at each marked location.
- REPEAT Section 3.3 for opposite side.

#### **3.3.2 For 1 3/4" jambs only:**

- For 1 3/4" jambs, doorway holding beams are factory installed.

**Figure 4. Locating the Doorway Holding Beams**

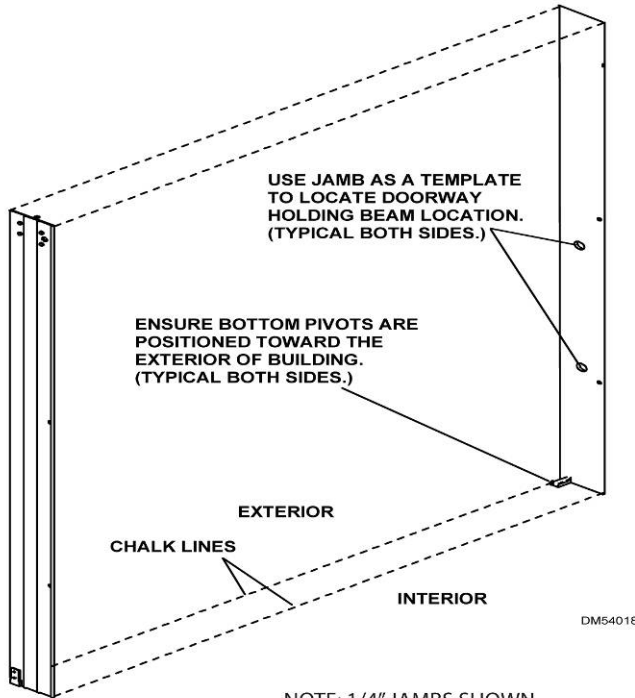

**3.4 Installing the Overhead Sensors**

3.4.1 Refer to manufacturer's installation instructions, and **INSTALL** motion/safety sensors on each side of the header at the center of the full-door-open position.

**3.5 Connecting the Holding Beams**

3.5.1 Refer to manufacturer's installation instructions, and **CONNECT** doorway holding beams.

**3.6 Installing the Header and Jamb Assembly**

3.6.1 Refer to Figure 5. Using four lock washers or Loctite® and four 1/4-20 x 1/2" bolts per side, **FASTEN** the jambs to the header.

**NOTE: 1/4" JAMBS SHOWN**  
**FIGURE 5. Attaching the Jamb to the Header**

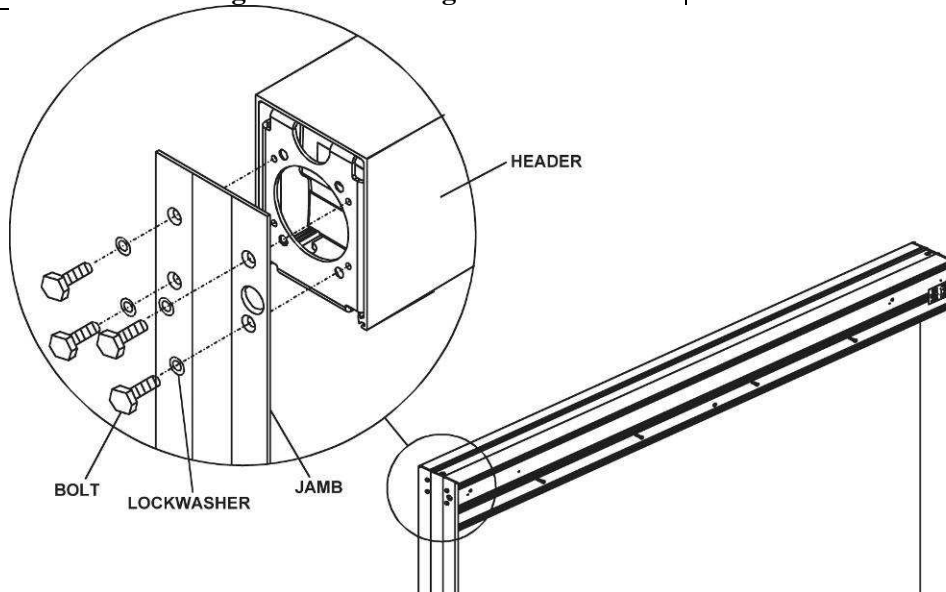

3.6.2 Refer to Figure 6, and using the two 1/4-20 x 1/2" screws, **FASTEN** the SO pivot block to the jamb.

- 3.6.3 SET the initial height of the SO pivot so that the shoulder of the SO pivot is  $\frac{9}{16}$ " above the top of the pivot block when installed with a threshold.
- 3.6.4 THREAD the SO pivot with jamb nut into the SO pivot block.
- 3.6.5 REPEAT Steps 3.6.2 through 3.6.4 for opposite SO pivot block.

**Figure 6. Installing the Jamb Pivot Blocks**

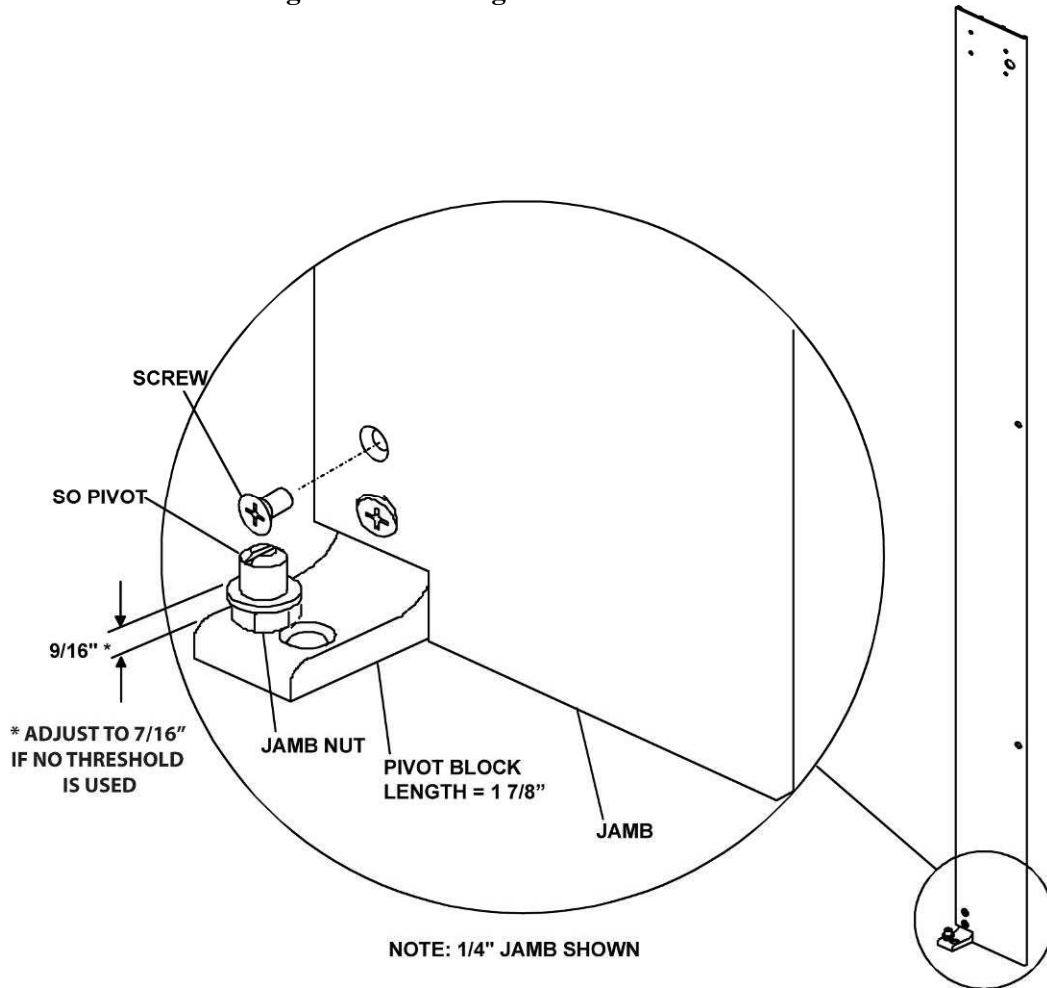

- 3.6.6 **For  $\frac{1}{4}$ " jamb only:** ROUTE the doorway holding beam wires (without heads attached) through the back of the jambs and into the header.
- 3.6.7 **For  $\frac{1}{4}$ " jamb only:** Using tape, ATTACH the doorway holding beam wires to the jamb channel.
- 3.6.8 At the exterior and interior sides of the opening, MARK chalk lines on floor from one jamb to the other.
- 3.6.9 LIFT header and jamb assembly and POSITION assembly so header cover faces *interior*.



**Figure 7. Aligning the Header and Jamb**

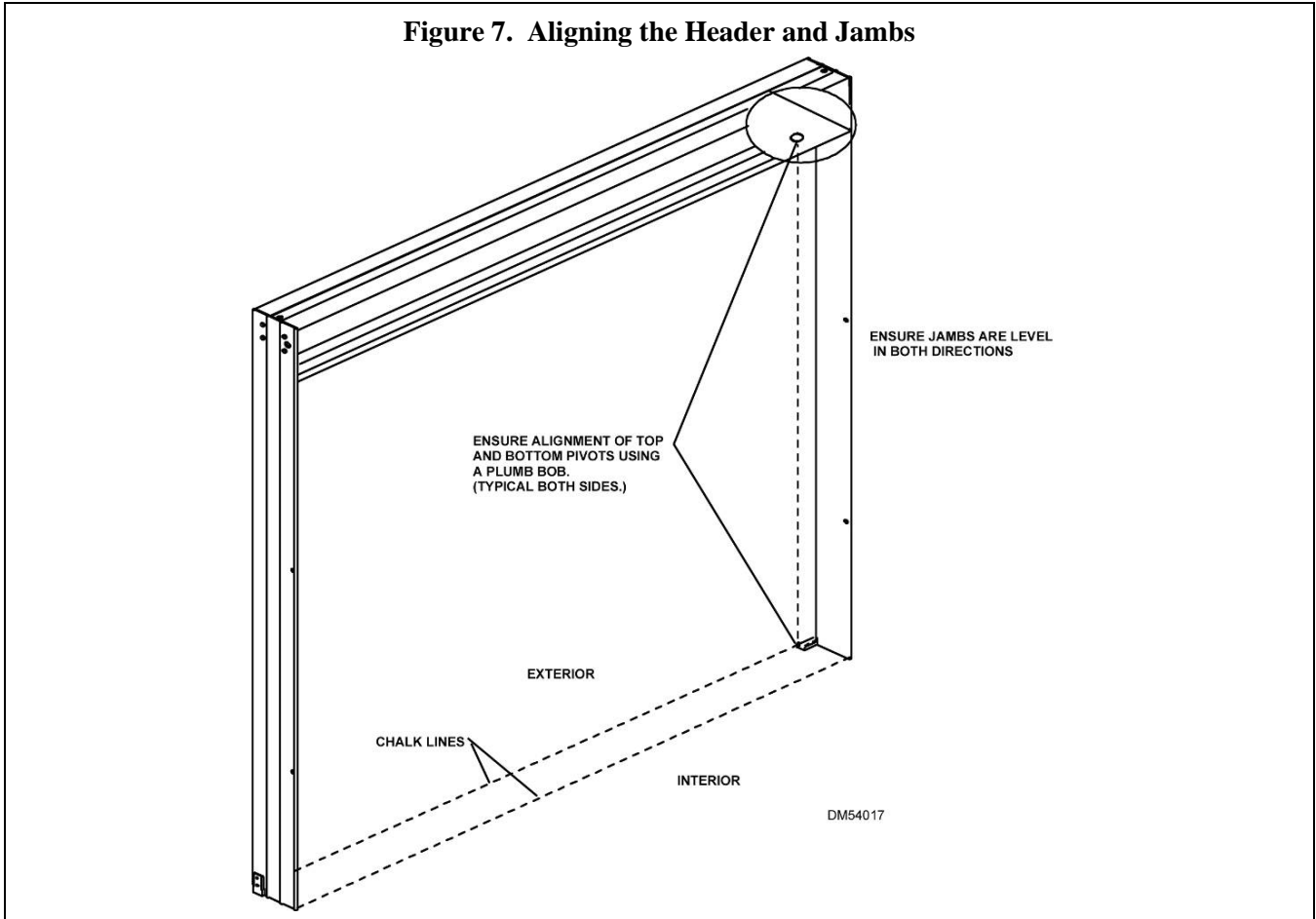

- 3.6.10 Refer to Figure 7, and **ALIGN** the jambs to the chalk lines drawn in step 3.6.8.
- 3.6.11 Temporarily **SECURE** in place as necessary to prevent header and jamb assembly from falling.
- 3.6.12 **SHIM** beneath jamb(s) as necessary to level header and maintain required height from highest point of finished floor.
- 3.6.13 Evaluate the opening, then **DRILL** and **COUNTERSINK** four 1/4" holes evenly spaced vertically along each jamb.
- 3.6.14 **INSPECT** one jamb for plumb in vertical and horizontal planes. **SHIM** as necessary.
- 3.6.15 Using the pre-drilled jamb holes as a guide, **DRILL** holes in rough opening for the following fasteners as required:

**Chart 1. Jamb Installation Fastener Size and Type**

Rough Opening	Fastener size/type	Embedded minimum depth
Concrete	concrete screw	1 1/2"
Steel	#14/SMS (18 GA steel minimum)	n/a
Wood	#14/wood screw	1 1/2"

- 3.6.16 **INSTALL**, but do *not* tighten, fasteners securing one jamb to opening, and **ENSURE** jamb remains plumb.
- 3.6.17 **INSPECT** opposite jamb for plumb in vertical and horizontal planes. **SHIM** as necessary.
- 3.6.18 Starting at the top of jamb and moving downward, ensure jambs remain level and plumb, and **TIGHTEN** fasteners securing jambs to opening.
- 3.6.19 **ENSURE** the following:
- Assembly is square and centered in the door opening.
  - Header is level.
  - Jambs are plumb along the entire height of the jambs.
  - Jambs are square to the rough opening.
  - Top and bottom pivots are aligned.

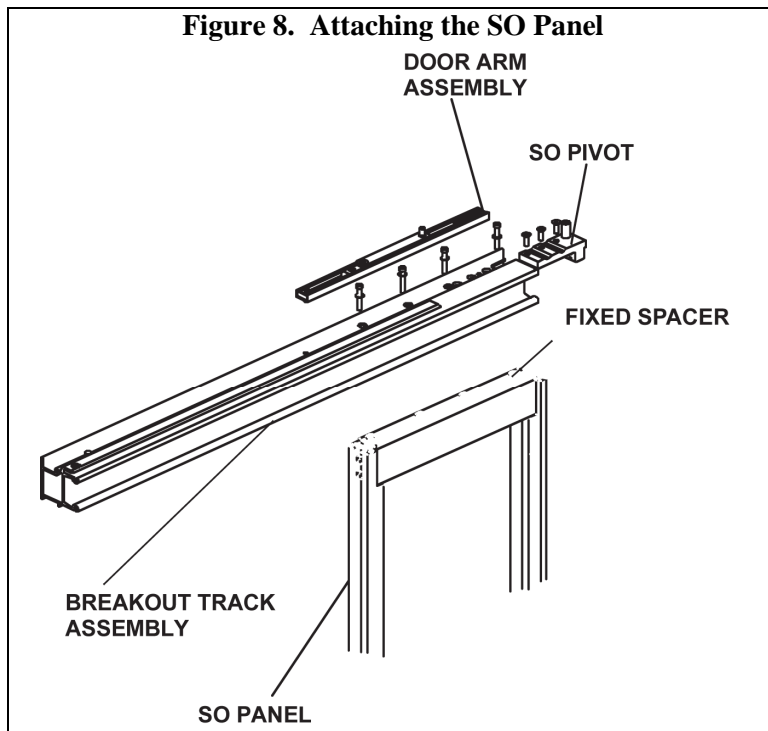

for opposite SO panel.

### 3.8 Threshold Installation

- 3.8.1 **For door systems with threshold:** Cut off 1 7/8" of appropriate profile (squared or beveled) from each side for pivot block clearance. Refer to Figure 6.
- 3.8.2 Install threshold.

### 3.7 Attaching the SO Panel to the Breakout Track

- 3.7.1 **REMOVE** the three screws securing the top SO pivot to the breakout track and **REMOVE** the top SO pivot. See Figure 8.
- 3.7.2 **REMOVE** the four screws securing the fixed spacer of the SO panel.
- 3.7.3 To **ENSURE** proper door and breakout direction and handing, first **ALIGN** top pivot of breakout track with pivot block on panel.
- 3.7.4 Using the four screws removed in step 3.7.2; **FASTEN** the breakout track to the top rail of the SO panel.
- 3.7.5 **FASTEN** the SO pivot.
- 3.7.6 Using the 1/4 - 20 x 7/8" screws provided with the door arm, **FASTEN** the door arm to the top of the breakout track.
- 3.7.7 **REPEAT** steps 3.7.1 through 3.7.6

## **NOTE**

ADJUST gap between header and breakout track **BEFORE** engaging the SO pivot.

### 3.9 Installing the SO Panel

- 3.9.1 POSITION the bottom of the SO panel over the SO pivot.
- 3.9.2 ADJUST the SO pivot to ensure that the SO panel is located at its highest point in order to account for panel sag. The gap should be 1/16" or less between header and panel.
- 3.9.3 PRESS the spring-loaded top SO pivot downward, and SWING the SO panel into position until the spring-loaded pivot locks into header.
- 3.9.4 ENSURE that the SO panel breaks out freely.
- 3.9.5 Using the  $\frac{5}{16}$ " X  $\frac{5}{8}$ " screws FASTEN the door arm to the header.
- 3.9.6 REPEAT Section 3.9 for opposite SO panel.

### 3.10 Installing the Fast Panels

3.10.1 IF Access Control is an option then refer to attachment 8 and install the Panic bar.

3.10.2 Refer to Figure 9 and temporarily adjust hanger rollers as shown, leaving upper roller nuts **LOOSE** until bottom rollers are placed onto track.

3.10.3 Carefully **LIFT** fast panel and **POSITION** hanger onto header track.

3.10.4 **ADJUST** hanger rollers as necessary to ensure that rollers are engaged in header track and the door will not fall. **ENSURE** arrows are pointed outwards and are a mirror image of each other.

3.10.5 **REPEAT** Section 3.10 for opposite fast panel.

3.10.6 **ENSURE** fast panel heights are the same.

### 3.11 Installing the Slow Panels

3.11.1 Refer to Figure 9 and temporarily adjust hanger rollers as shown.

3.11.2 Carefully **LIFT** slow panel and **POSITION** it onto the bottom guides of the SO and fast panels. **SWING** the panel upward and **POSITION** the hanger onto header track. See Figures 10 & 11 (next page).

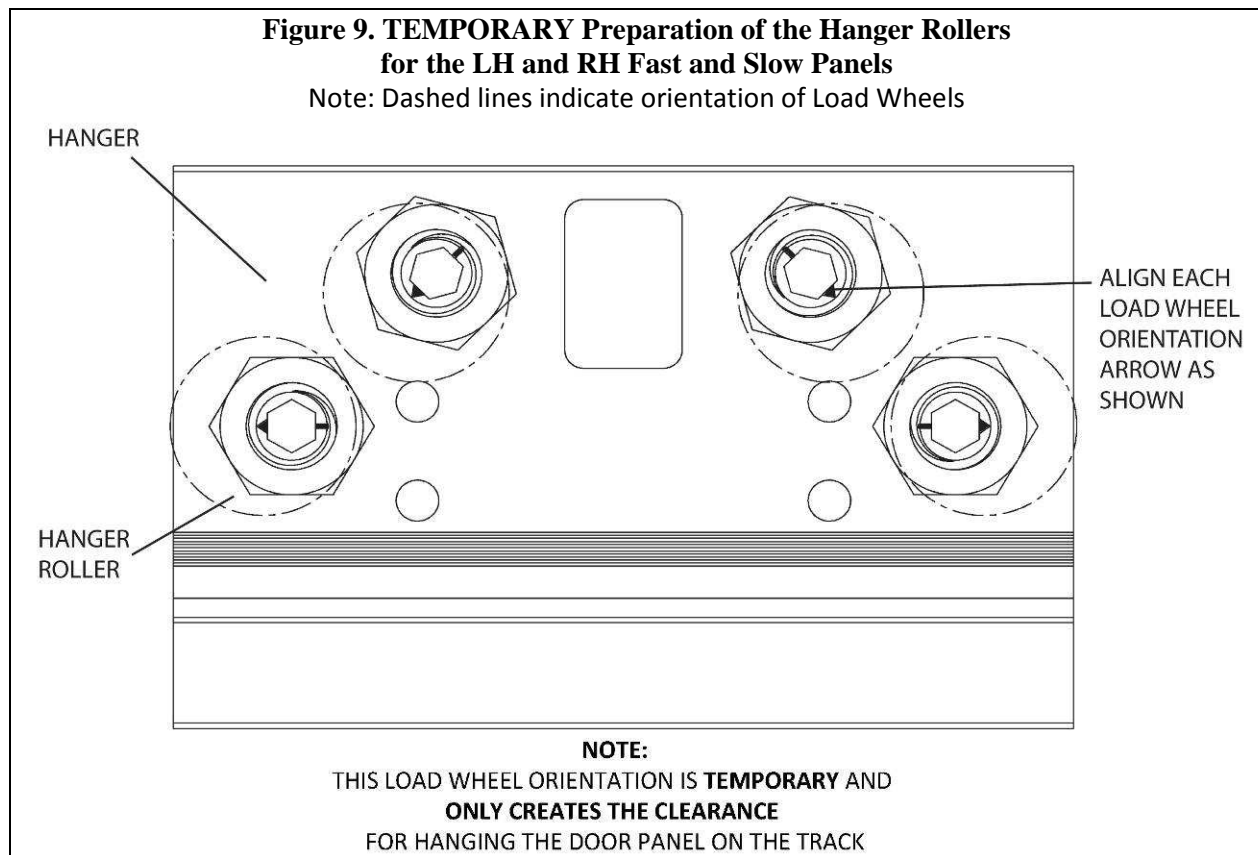

3.11.3 **ADJUST** hanger rollers as necessary to ensure that rollers are engaged in header track and the door will not fall.

3.11.4 **REPEAT** Section 3.11 for opposite slow panel.

Figure 10. SX Slow Panel Installation 1

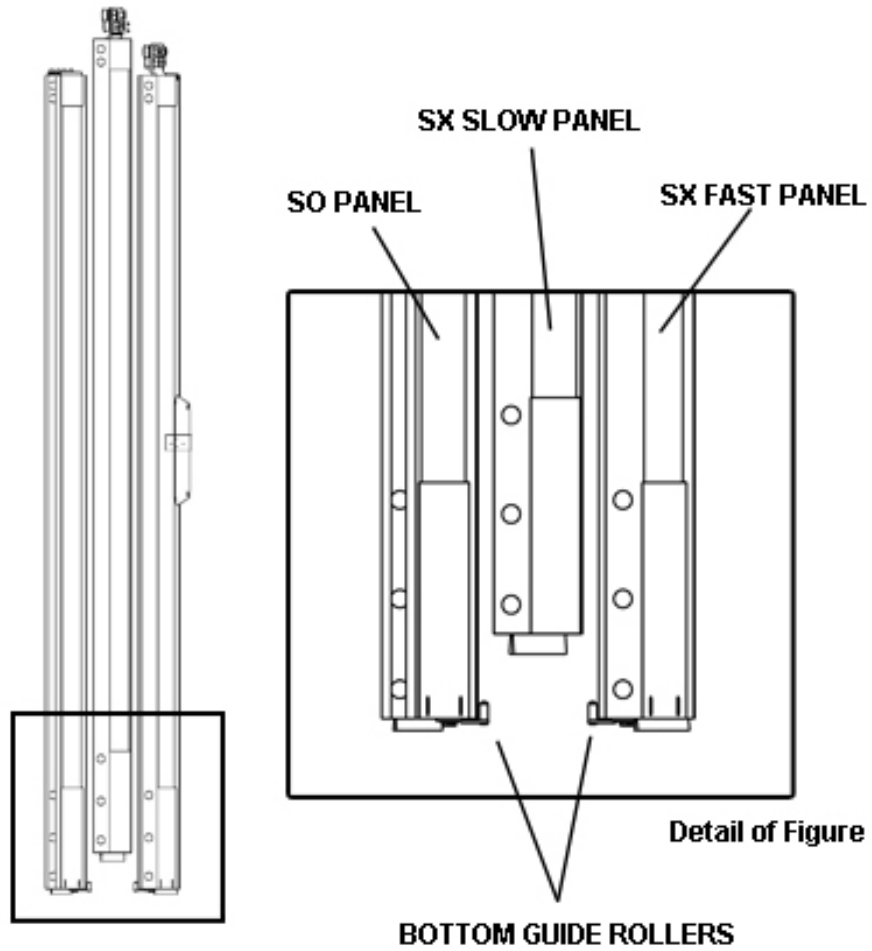
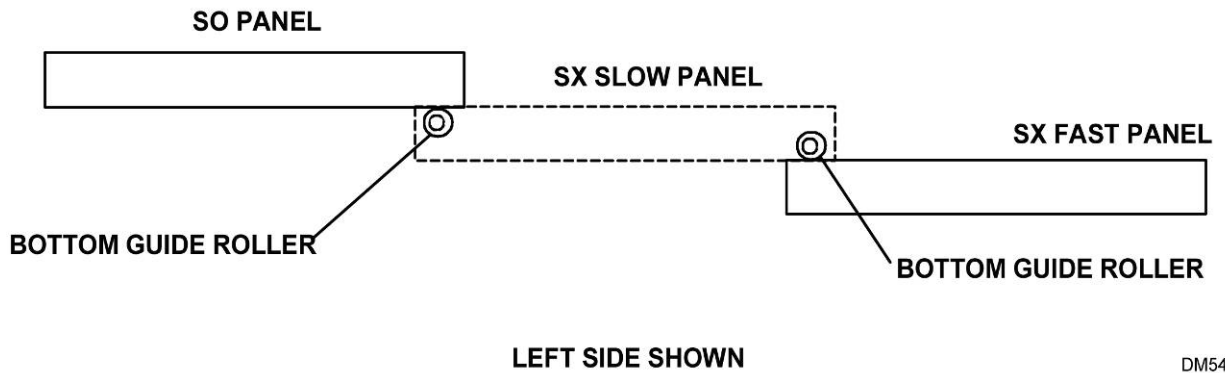

Figure 11. SX Slow Panel Installation 2



DM54023

### 3.12 Adjusting the Panels

3.12.1 MOVE doors to the fully closed position.

3.12.2 Refer to Figures 12a, 12b and 12c and ADJUST the LH and RH Fast and Slow Panel load wheels as necessary.

- Doors should always be adjusted to the same height if conditions allow it.
- Load wheels on the left and right side of each hanger need to face away from each other as a “mirror image”

Note:

Load wheels can collide with each other. Make sure that they are adjusted against the track.

**Figure 12a. Adjusting the Hanger Rollers on the LH and RH Fast and Slow Panels 1**

Note: Dashed lines indicate orientation of Load Wheels

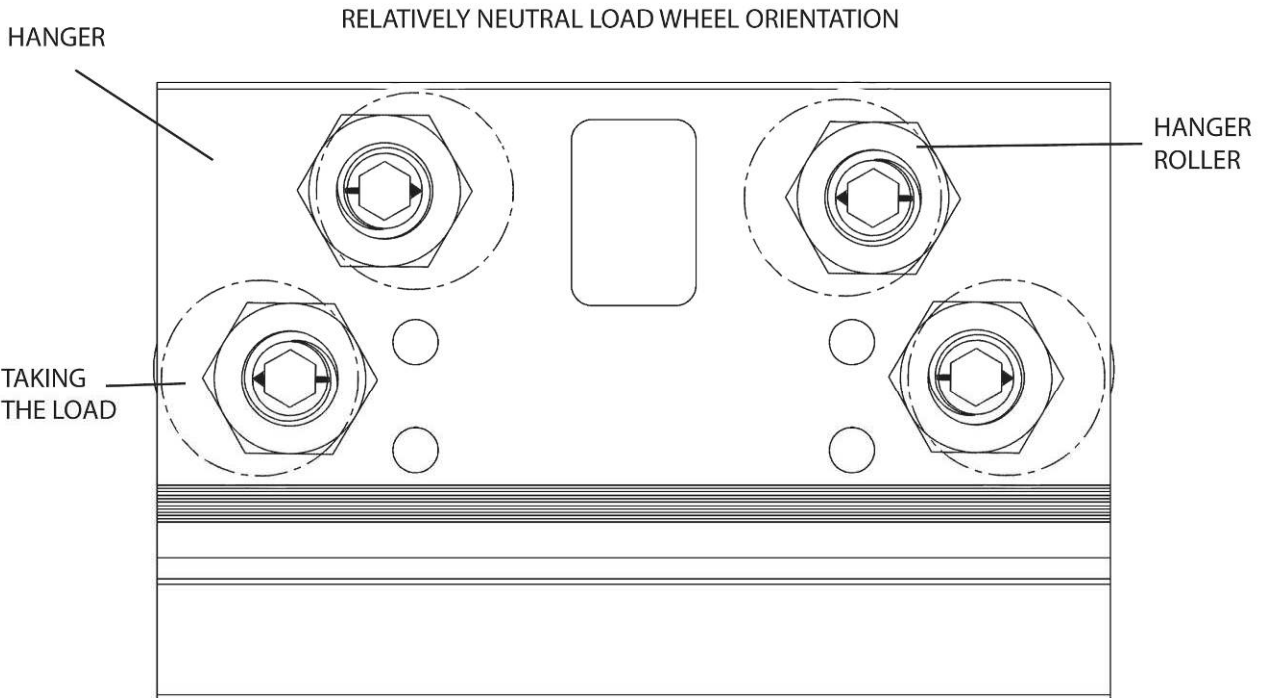

**Figure 12b. Adjusting the Hanger Rollers on the LH and RH Fast and Slow Panels 2**

Note: Dashed lines indicate load wheel orientation

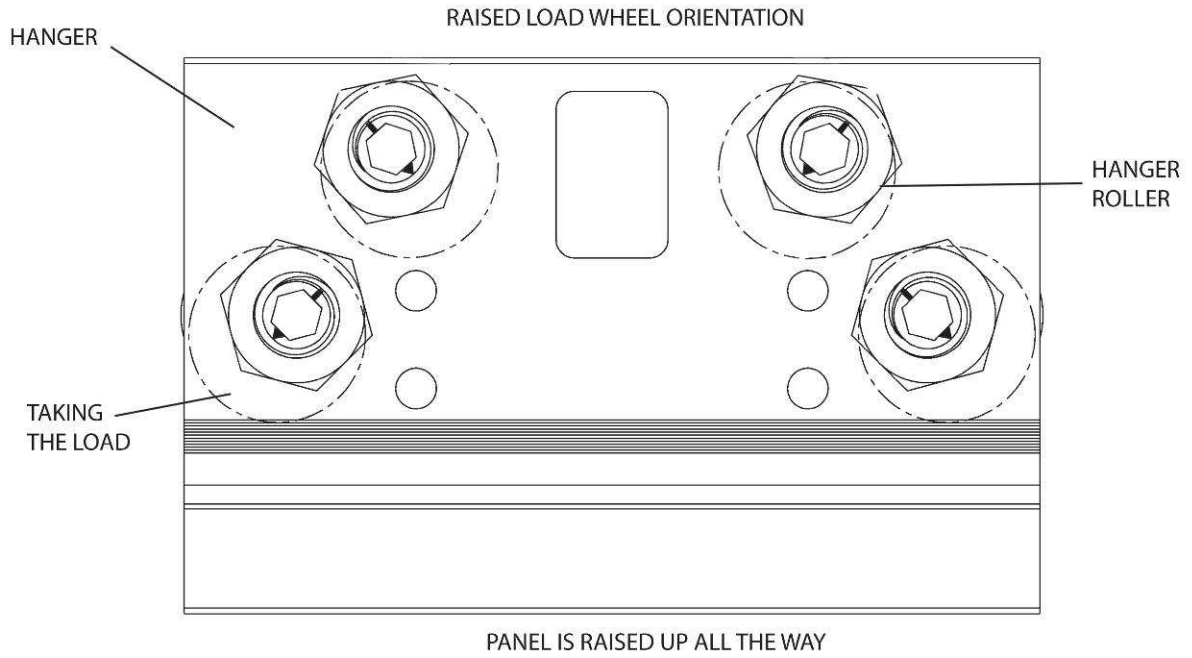

**Figure 12c. Adjusting the Hanger Rollers on the LH and RH Fast and Slow Panels 3**

Note: Dashed lines indicated Load Wheel Orientation

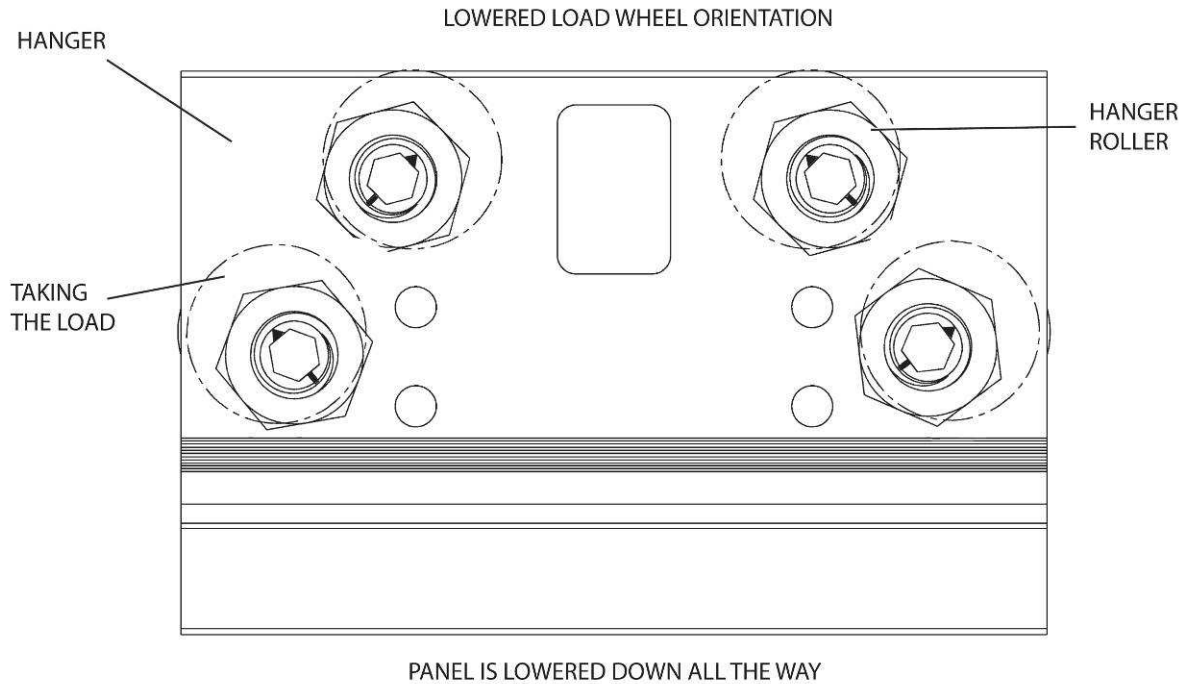

3.12.3 Refer to Figure 13, and INSPECT the alignment of all four door panels within the opening. ADJUST the door panels using 3/8" socket drive with 5/16" Allen tip and 15/16" box-end offset wrench as necessary to:

- ENSURE the stiles are perfectly plumb
- ADJUST one bottom roller to obtain proper door height
- ADJUST second bottom roller to just engage bottom track
- ADJUST top two rollers to obtain a slight upward pressure

**Figure 13. Adjusting the Door Panels**

**NOTE**

When rollers are properly engaged, slight friction is expected. DO NOT over tighten.

FAST AND SLOW PANEL STILES  
OVERLAP EVENLY ALONG ENTIRE  
HEIGHT OF PANELS

LEADING EDGES MATE SQUARELY

PANEL TOPS ARE EVEN ACROSS  
LENGTH OF OPENING

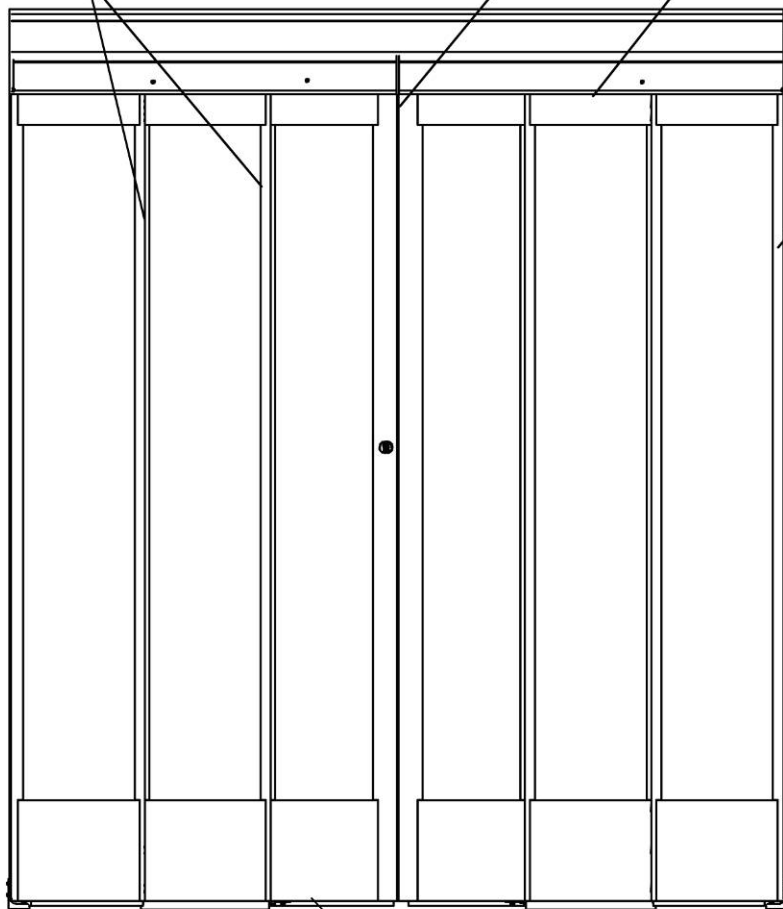

MINIMAL GAP BETWEEN  
JAMB AND SO PANEL.  
GAP CONSISTENT ALONG  
ENTIRE HEIGHT OF PANELS.

Ensure the vertical leading edges  
overlap squarely, the vertical gaps  
between panels are minimal and the  
panels are horizontally even.

PANEL BOTTOMS ARE EVEN  
ACROSS LENGTH OF OPENING



### NOTE

ENSURE slow panels are adjusted properly prior to installation of timing assembly.

#### 3.13 Installing the Panel Timing Assembly

3.13.1 REMOVE and DISCARD temporary nuts that secure the #10 Allen screws to the timing bracket.

3.13.2 FASTEN timing bracket using two #10 Allen screws into top pivot.

3.13.3 SECURE two 10-24 x 1/2" self-threading screws through upper timing bracket and into fast panel top rail.

3.13.4 FASTEN timing pulley bracket to slow panel hanger using four 8-32 x 1" Phillips-head screws and lock washers or Loctite®. ENSURE timing pulley bracket fully engages the hanger groove. See Figure 14.

### NOTE

If small pulleys are not synchronized, the slow panel will not be flush with the SO and fast panels.

3.13.5 ADJUST timing pulley while door is in the full open position. Loosen shoulder bolt on timing belt wheel, then slide the wheel, and adjust as necessary. ENSURE doors open and close fully and the belt is tight.

3.13.6 REPEAT for other side.

**Figure 14. Installing the Panel Timing Bracket**

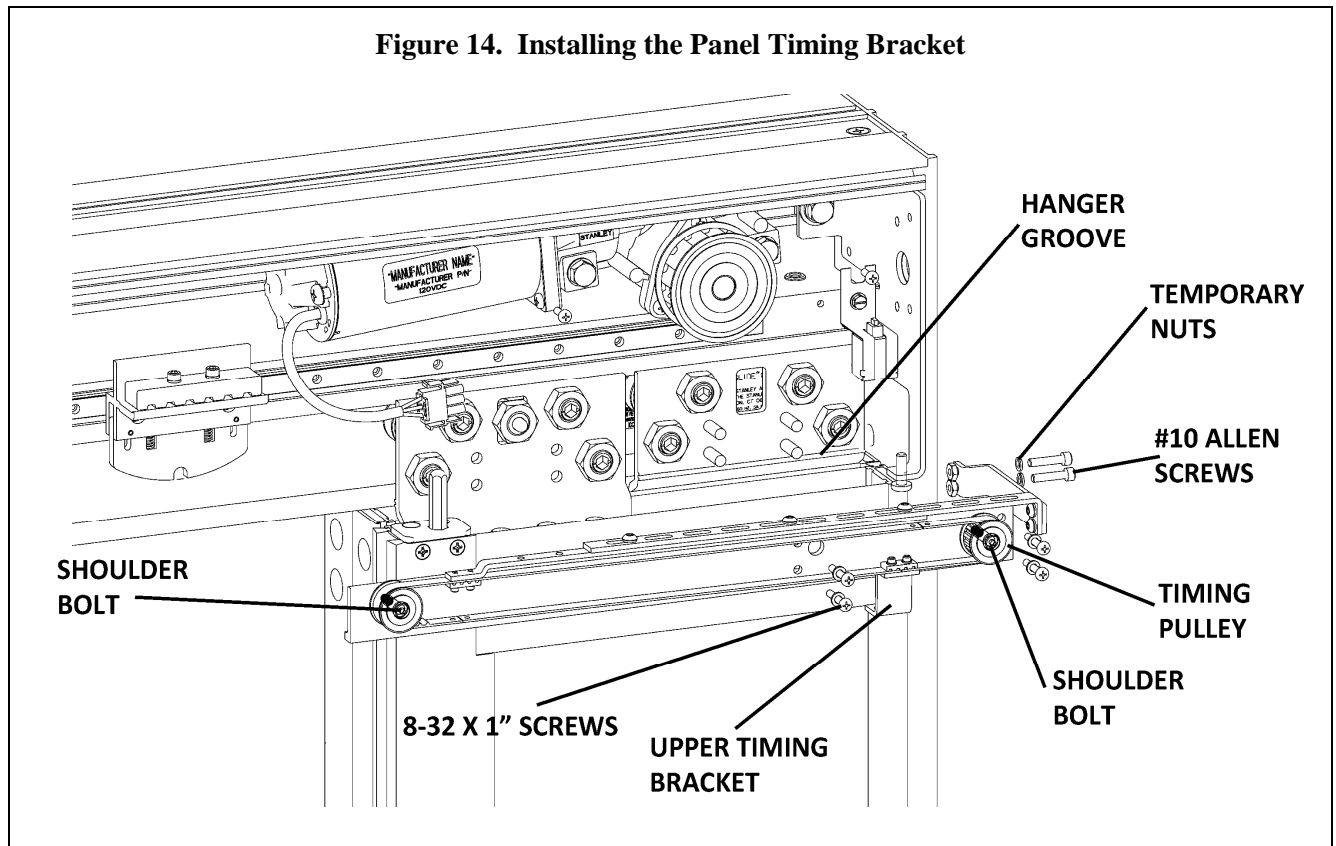

## NOTE

1. The side-by-side position of the drive pin is factory set. The up-down position must be adjusted in the field.
2. The proper engagement of the drive pin is achieved when the clearance between the pin and carriage blade is zero.

3.13.7 Refer to Figure 15, and, using the adjusting nut, ADJUST the up-down position of the pickup pin until the pickup pin properly engages with the carriage blade.

**Figure 15. Installing the Panel Timing Assembly**

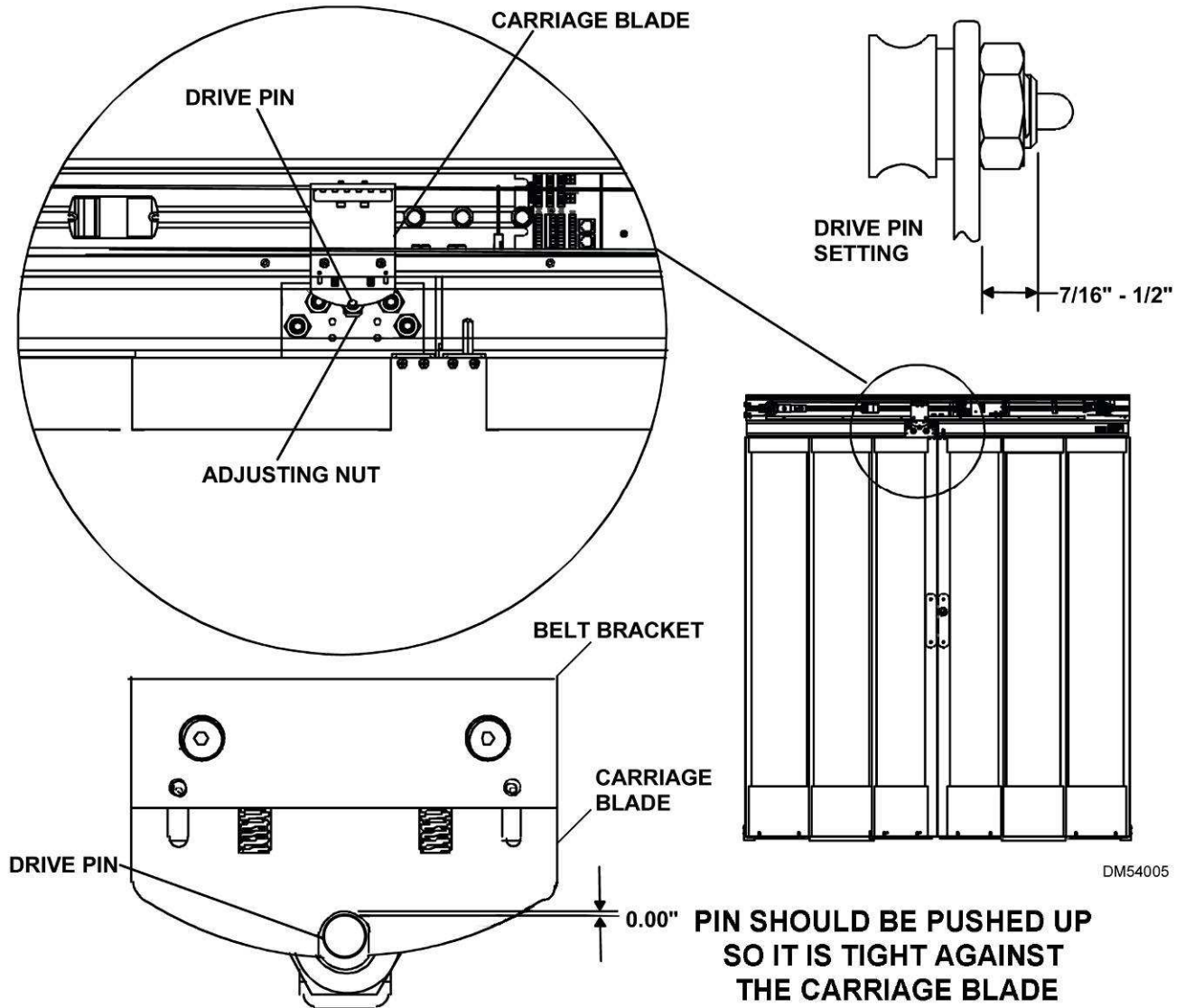

**Figure 16. Installing Header Seal**

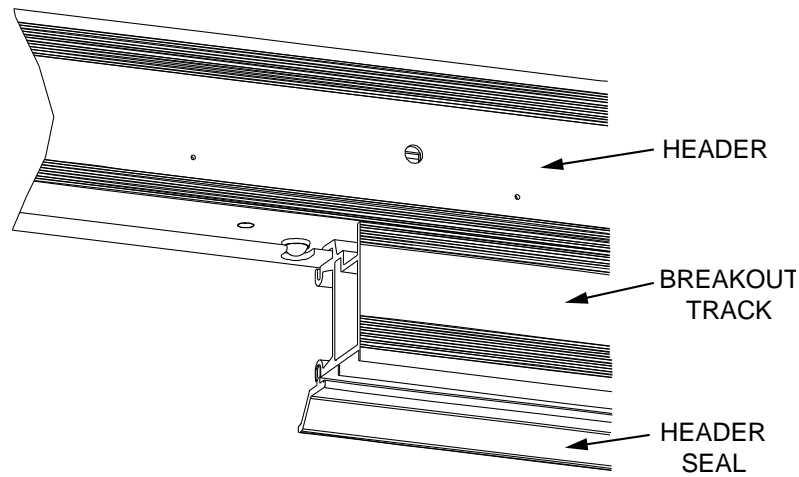

**3.14 Installing Header Seal & Weather stripping**

**3.14.1 Header Seal**

- a. **SLIDE** header seal into breakout track and **PEEN** over edges to seal and ensure it does not move.

**3.14.2 Weather stripping**

- a. **INSTALL** weather stripping, cut to size

**3.15 Adjusting the Bottom Sweeps**

- 3.15.1 Refer to Figure 17, and, **ADJUST** the fast and fixed panel bottom sweeps as low as possible without affecting the proper operation of the bottom guides.

- 3.15.2 **ADJUST** the slow panel compression sweeps as low as possible without affecting the proper operation of the bottom guides.

**Figure 17. Adjusting the Bottom Sweeps**

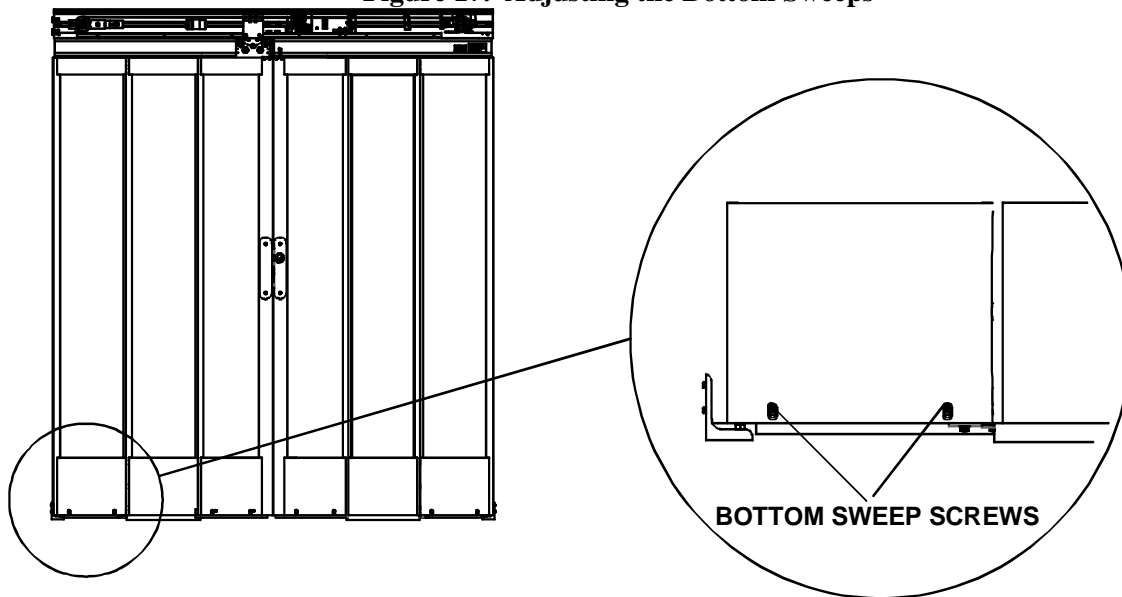

DM54020

### 3.16 Performing the Final Adjustments

- 3.16.1 CYCLE doors several times, and ENSURE doors open and close freely.
- 3.16.2 Refer to manufacturer's installation instructions, and Stanley Access Technologies document No. 204066, MC521 Pro Controller Installation and Operation Manual" for sensor wiring and settings.
- 3.16.3 ENSURE locking mechanism works properly and breakout force is properly adjusted.
- 3.16.4 Refer to "Attachment 6: Dura-Max 5400-Series Options" for options installation instructions and applicable wiring diagrams.
- 3.16.5 Refer to Stanley Access Technologies document No. 204066, "MC521 Pro Controller Installation and Operation Manual," and ADJUST controller.

### 3.17 MC521 Pro Control Box Monitoring Setup

Remove the JP200 jumper on the MC521 Pro, located between the two Encoder Connectors for Sensor Monitoring.

#### **NOTE**

**IF THE JP200 IS REMOVED PERMANENTLY, THIS MC521 PRO CONTROL BOX CANNOT BE USED ON ANOTHER DOOR WITH A STANGUARD SENSOR.**

- 3.17.1 The JP200 jumper is an internal MC521 Pro connection that enables TB-3-4 to be used as an input and output required for StanGuard.
- 3.17.2 Enable Sensor Monitoring. Refer to Stanley Access Technologies document No. 204066, MC521 Pro Controller Installation and Operation Manual" for sensor monitoring selections.

3.18 Performing the Closeout Procedure

- 3.18.1 ENSURE glass is not cracked or broken.
- 3.18.2 ENSURE glass and metal surfaces are clean.
- 3.18.3 ENSURE all labels are properly installed.
- 3.18.4 ENSURE door installation area is clean and free of debris.
- 3.18.5 ENSURE header is secured firmly.

**CAUTION**

1. Caulk joints of ¼ inch are typical. If caulk gap exceeds ½ inch, the Installation Coordinator must be consulted to determine corrective actions.

2. The header cover joint must *never* be caulked.

3.18.6 **I**F required, CAULK the following as specified in door specification, work order, or construction documents:

- Top of header
- Sides of jambs

3.18.7 COMPLETE Work Order and REPORT your actions to Building Superintendent.

3.19 Replacement Parts

- 3.19.1 Refer to Attachment 2 for a listing of replacement parts.

**Attachment 1**  
**Documents, Definitions, Special Tools, Equipment, Materials, and Consumables**  
(Sheet 1 of 1)

**Documents**

- Stanley Access Technologies document No. 204066, “MC521 Pro Controller Installation and Operation Manual”
- Manufacturer’s installation instructions for the motion/safety sensor

**Definitions**

- None

**Special Tools in addition to typical install tools** (including, but not limited to)

- 15/16” box-end offset wrench
- 3/8” socket drive with 5/16” Allen tip
- 3/8” drive 10” breaker bar

**Materials** (including, but not limited to)

- Concrete expansion shields
- Lag bolts

**Consumables** (including, but not limited to)

- Clean rags
- Glass cleaner
- Silicone caulk

## Attachment 2 Replacement Parts

(Sheet 1 of 7)

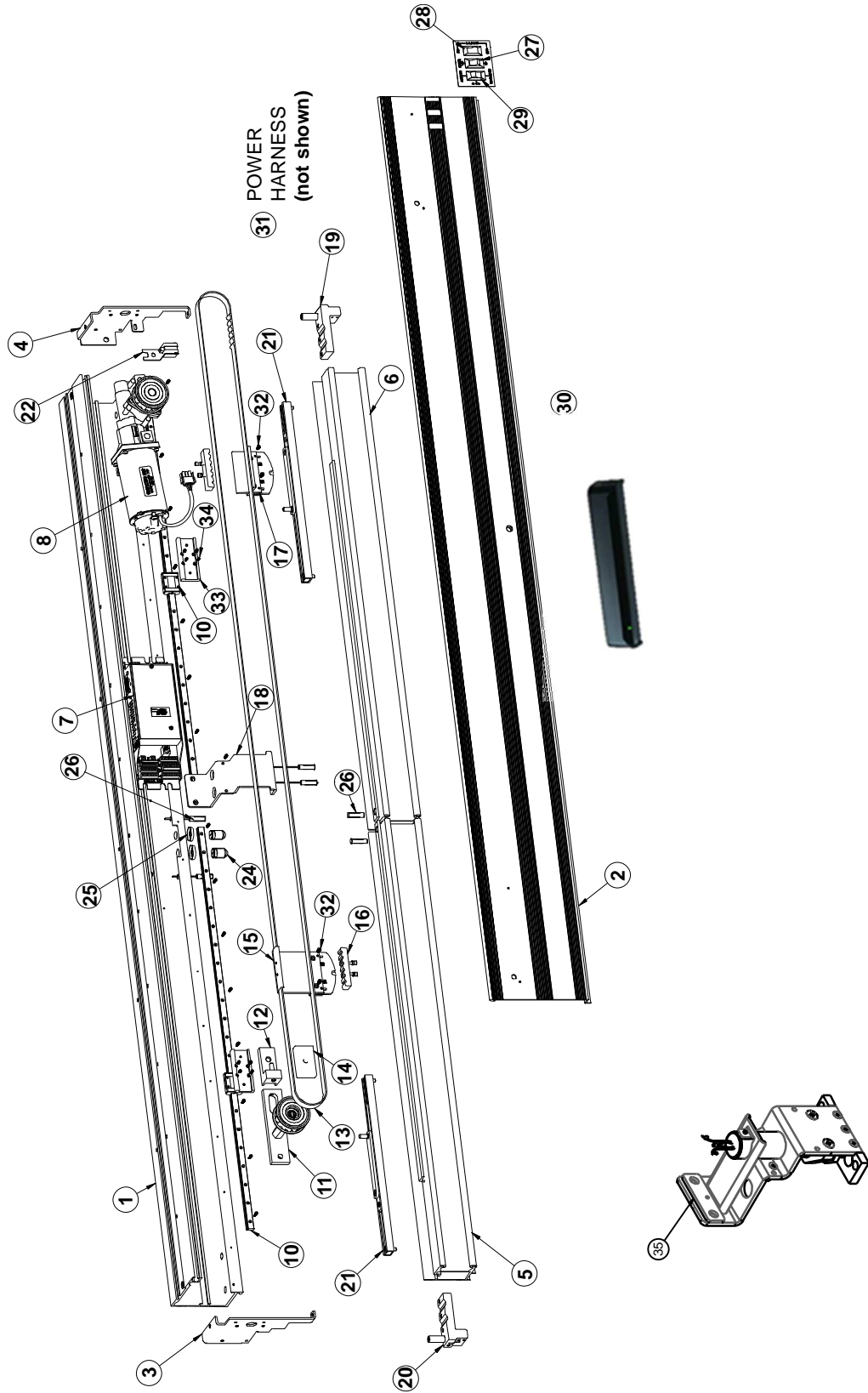

REPLACES PART #18 WHEN SOLENOID LOCK OR ACCESS CONTROL OPTION IS SELECTED

**Attachment 2**  
**Replacement Parts**  
 (Sheet 2 of 7)

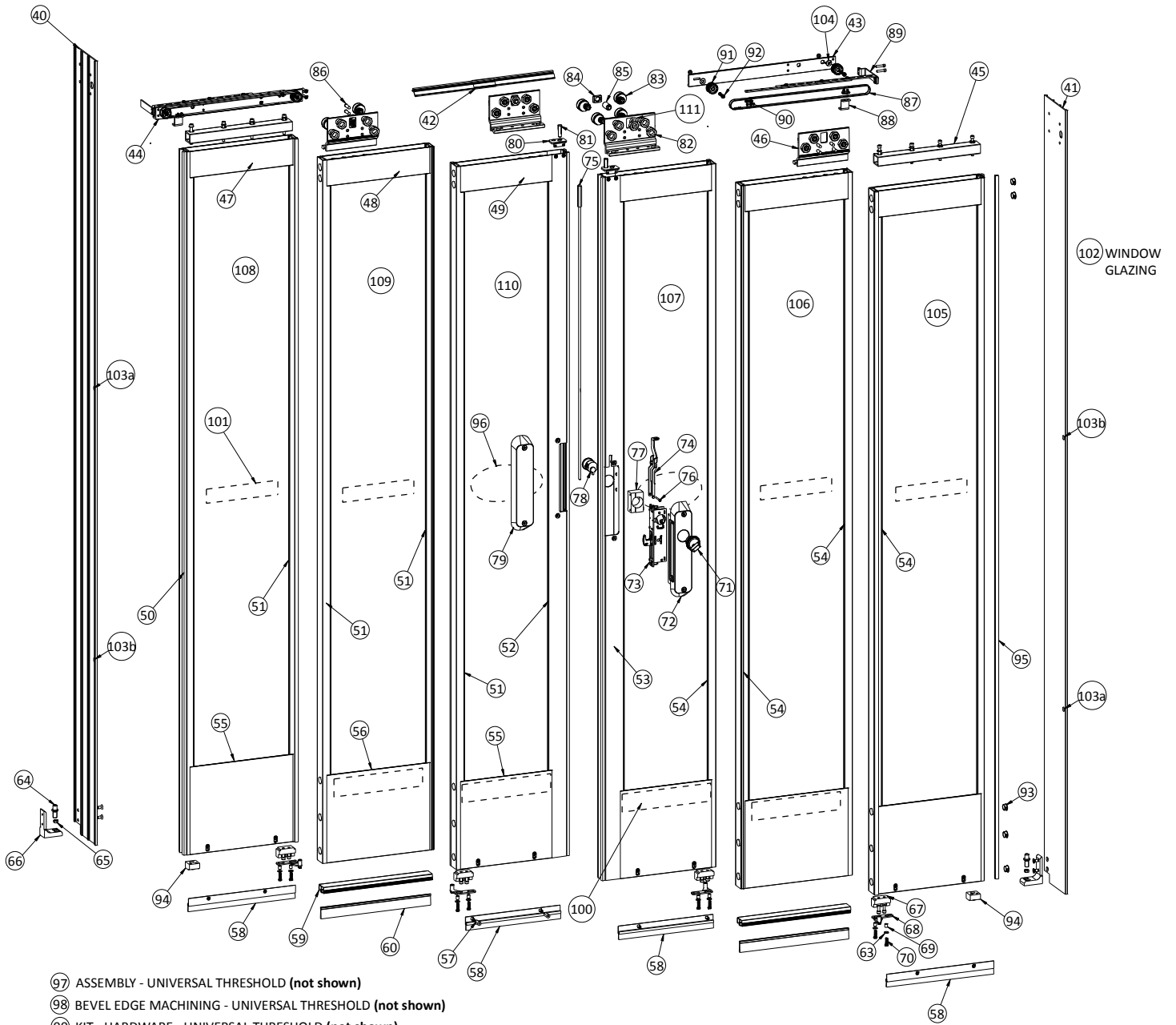

**NOTE:**

1. FOR PANEL TIMING ASSEMBLY, SEE DETAIL A
2. FOR LOCK ASSEMBLY, SEE DETAIL B
3. FOR BOTTOM GUIDE, SWEEP AND PIVOT ASSEMBLY, SEE DETAIL C
4. FOR HANGER ASSEMBLY, SEE DETAIL D



**Attachment 2**  
**Replacement Parts**  
 (Sheet 3 of 7)

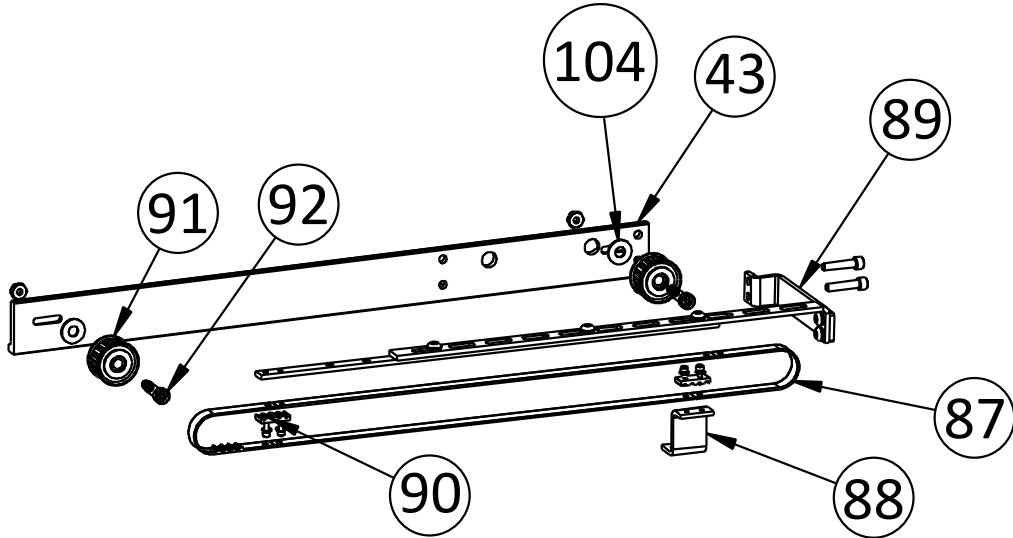

**DETAIL A**  
**PANEL TIMING ASSEMBLY**

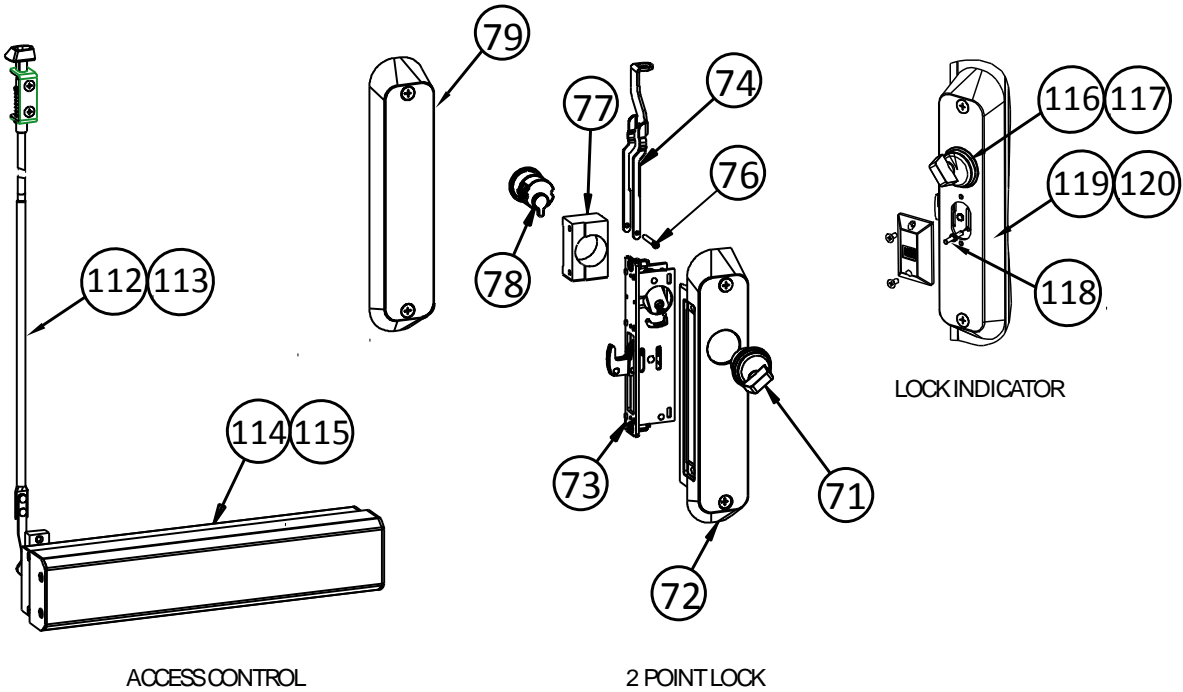

ACCESS CONTROL

2 POINT LOCK

LOCK INDICATOR

**DETAIL B**  
**PANEL LOCK ASSEMBLY AND ACCESS CONTROL**

**Attachment 2**  
**Replacement Parts**  
(Sheet 4 of 7)

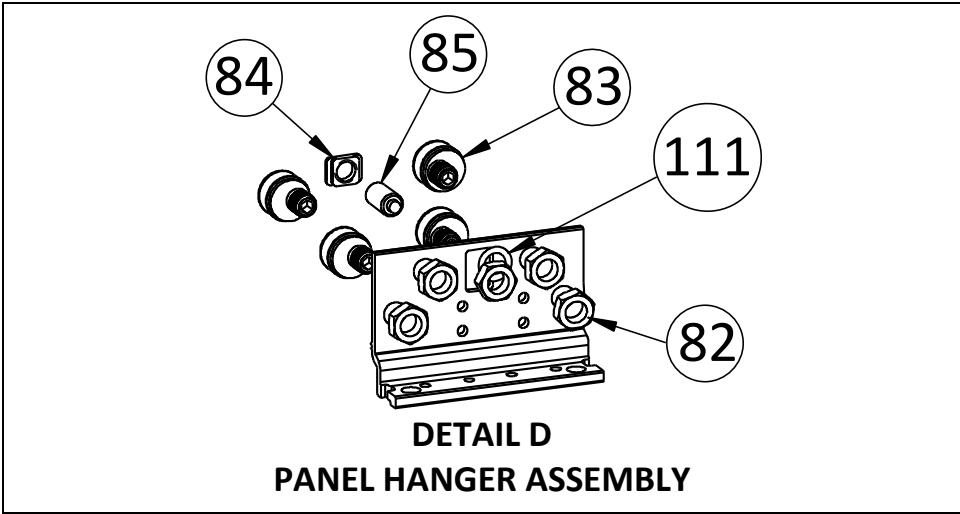
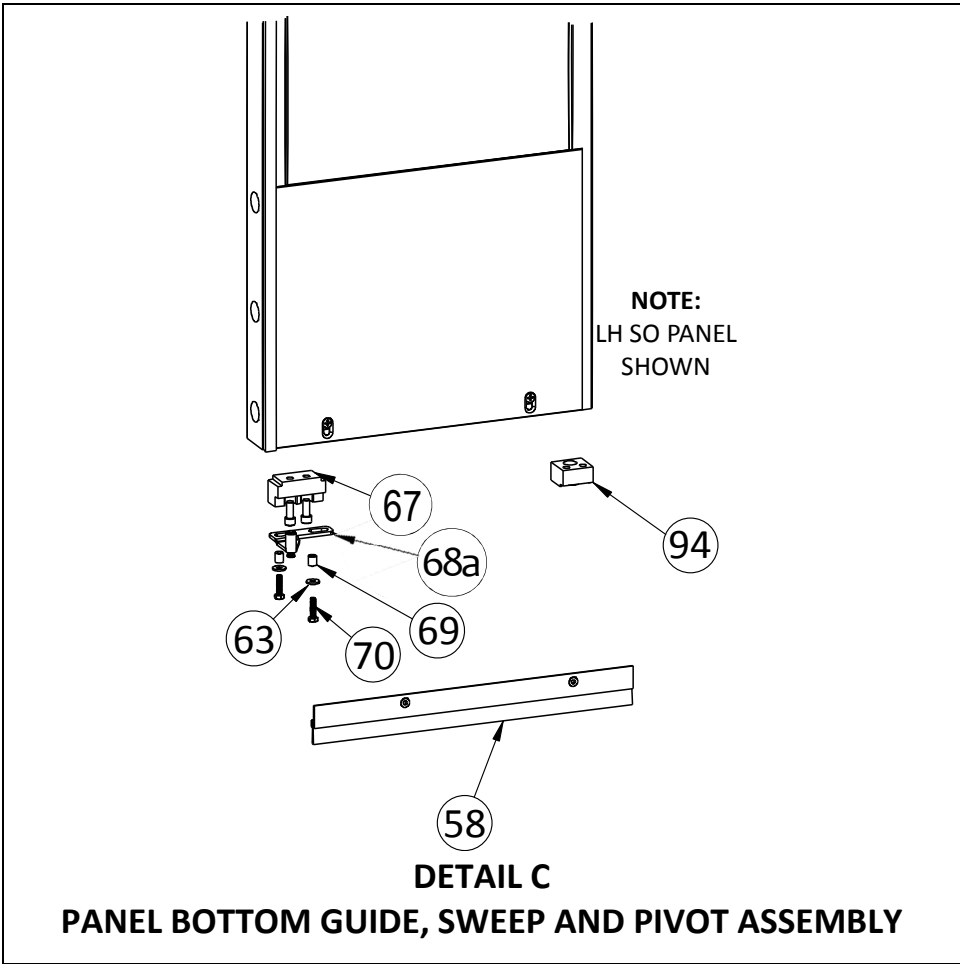

**Attachment 2**  
**Replacement Parts**  
(Sheet 5 of 7)

Item	Part No.	Qty/ Length	Description	Item	Part No.	Qty/ Length	Description
<b>HEADER ASSEMBLY (1 of 1)</b>							
1	517085		HEADER, UPPER	26	711463	2	MAGNET ALARM/BREAKOUT SWITCH SET
2	517087		HEADER, COVER	27	713080	1	SWITCH – ROCKER ONEWAY/RED OPEN
3	191118-2	1	END PLATE BRACKET – HEADER (RIGHT)	28	713081	1	SWITCH-ROCKER POWER W/LIGHT
4	191118-1	1	END PLATE BRACKET – HEADER (LEFT)	29	713082	1	SWITCH-ROCKER AUTO/CLS/OPEN
5	517086		HEADER, LOWER BREAKOUT, RH	30	700447	2	SENSOR X-ZONE ST
6	517086		HEADER, LOWER BREAKOUT, LH	31	517196*	1	HARNESS POWER-DURAMAX 5400
7	314117	1	MC-521 PRO CONTROLLER RPC	32	714531	4	SCREW SOCKET HEAD FLAT #8-32 x 7/16"
8	972313027	1	MOTOR & GEARBOX ASSY	33	417218	2	ADAPTER BLOCK
10	714537-1^, 714537-2^	2	BALL BEARING SLIDE AND TRACK	34	714535	8	LOW HEAD CAP SCREW M3 X 6MM
11	515059	1	IDLER ASSY	<b>OPTIONS</b>			
12	413348	1	ANCHOR ASSEMBLY	35	417281-1	1	SOLENOID LOCK - FAIL SAFE
13	711450		BELT-TIMING-3/4"-, LONG LENGTH	35	417281-2	1	SOLENOID LOCK - FAIL SECURE
14	417023	1	BLOCK ADJUSTMENT-IDLER PULLEY		516871	1	SOLENOID LOCK-POWER SUPPLY
15	517105*	1	BELT BRACKET ASSY-LONG		714055	1	SOLENOID LOCK PLUG- TERMINAL BLOCK-10 POS.
16	NA		CLAMP-BELT		413550	1	ROTARY SWITCH ASSY
17	517104*	1	BELT BRACKET ASSY-SHORT		414107-1	1	HARNESS-ROTARY SWITCH TO CONTROL BOX
18	417029	1	PLATE- LOCKING-HEADER		413733-2	1	HARNESS-PWR-D/G-ROT/KEYSW 180"
19	517117-1*	1	PIVOT ASSY-HEADER-LH		313943	1	RETROFIT-DOOR POSITION SWITCH-SINGLE
20	517117-2*	1	PIVOT ASSY-HEADER-RH		313943-1	1	RETROFIT-DOOR POSITION SWITCH - DUAL
21	417066*	2	DOOR HOLDER ASSY		713899		KIT-JAMB CAMERA
24	708824	2	DETENT-BALL-SPRG LOADED-SO		713900	1	KIT-JAMB CAMERA POWER SUPPLY
25	NA		NUT-PALNUT-3/4-16		713901		HARNESS-VIDEO OUTPUT
					711463	2	SWITCH-MAGNETIC CONTACT
					714568	1	SPLITTER-POWER SUPPLY – 4 WAY

^714537-1 FOR UP TO 81" HEADER LENGTH, ^714537-2 FOR GREATER THAN 81" HEADER LENGTH

**\*SUGGESTED STOCK**

**Attachment 2**  
**Replacement Parts**  
(Sheet 6 of 7)

Item	Part No.	Qty/ Length	Description	Item	Part No.	Qty/ Length	Description
<b>PANEL ASSEMBLY (1 of 2)</b>							
40	NA		JAMB-MACHINING ¼-RH or 1 ¼" - RH	66	417035*	2	PIVOT BASE-JAMB MOUNTED – MACHINED
41	NA		JAMB-MACHINING ¼-LH or 1 ¼" - LH	67	417049*	4	MOUNTING BLOCK-BOTTOM GUIDE
42	NA		SEAL-DOOR EDGE CUSTOM	68a	417024-1*	2	BOTTOM GUIDE ASSY-LH
43	NA		BRACKET-TIMING PULLEY-MOUNTED-LH MACHINED	68b	417024-2*	2	BOTTOM GUIDE ASSY-RH
44	NA		BRACKET-TIMING PULLEY-MOUNTED-RH MACHINED	69	417221	8	BUSHING – 5/16 OD X 11/32L .192 ID
45	NA		HANGER, FIXED PANEL – MACHINED	70	714539	8	SCREW-HHC #10-24 X ¾ W/PATCH
46a	NA		HANGER, FAST/SLOW PANEL – MACHINED	71a	709221	1	THUMBTURN LOCK-CLEAR
47	NA		TOP RAIL – MACHINED SO	71b	709647	1	THUMBTURN LOCK - BLACK
48	NA		TOP RAIL – MACHINED SX SLOW	72a	517107-1	1	ESCUCHION PLATE, LOCK
49	NA		TOP RAIL – MACHINED SX FAST	73	515258	1	LOCK 1-POINT
50	NA		STILE, PIVOT, MACHINED	74	517103	1	OFFSET LINKAGE ARM, MORTISE LOCK
51	NA		STILE, LEAD, RH – MACHINED	75	413811-5	1	ROD ASSEMBLY, THROW BOLT 34-1/2
52	NA		STILE, LOCK, RH – MACHINED	76	417069*	1	ATTACHMENT PIN, LINKAGE ARM
53	NA		STILE, LOCK, LH – MACHINED	77	417055	1	BACKING PLATE, LOCK CYLINDER-FLUSH MNT
54	NA		STILE, LEAD, LH – MACHINED	78	714350	1	LOCK CYLINDER W/IC CORE - MORTISE
55	NA		10" BOTTOM RAIL – SO / SX FAST	79	517107-2	1	ESCUCHION PLATE, STRIKE
56	NA		10" BOTTOM RAIL – SX SLOW	80a	417071	2	LOCKING BAR GUIDE – MACHINED
57	714392	4	STANDOFF, MALE TO FEMALE, #10-32 X ¾"	82	NA		NUT-HEX JAM-#5/8-11 HEAVY
58	417179-09600*^	18"/panel	SWEEP HOLDER-BOTTOM-SO / SX FAST	83	714335*	8	LOADWHEEL - TELESCOPIC - 2 PC
59	5M7101-17500	18"/panel	BOTTOM GUIDE, SWEEP HOLDER –EXTRUSION	84	417181*	2	NUT-SPRING PLUNGER
60	710739-12000	18"/panel	BRUSH,BOTTOM SWEEP-SX SLOW	85	714365*	2	SPRING PLUNGER
63	382012499	8	WASHER-PLAIN-7/32 ID X ½ OD	86	714408	8	STANDOFF, #8-32 X .937" TALL
64	708950	2	PIVOT-BOTTOM-SO PANEL	87	417061*	10ft	TIMING BELT, 1/5" PITCH, 3/8" WIDE
65	380273499	2	NUT-HEX-JAM-7/16 -20	88	417060	2	BRACKET - TIMING BELT - LOWER
				89	417131	2	BRACKET - TIMING BELT

^DRILL AND ATTACH #10 RIV NUTS FOR REPLACEMENT

\* SUGGESTED STOCK

**Attachment 2**  
**Replacement Parts**  
(Sheet 7 of 7)

Item	Part No.	Qty/ Length	Description	Item	Part No.	Qty/ Length	Description
<b>PANEL ASSEMBLY CONT'D (2 of 2)</b>							
90	417057	4	CLAMP - TIMING BELT, 1/5" PITCH, MACHINED	105	NA		PANEL ASSY – LH - SO
91	714363*	4	TIMING PULLEY, 1/5" PITCH	106	NA		PANEL ASSY – LH - SLOW
92	714443*	4	SCREW-SHC ¼ X ¾ #10-32	107	NA		PANEL ASSY – LH - FAST
93a	714499	60	PLUG-SNAP IN-BLACK 5/8"	108	NA		PANEL ASSY – RH - SO
93b	714499-1	60	PLUG-SNAP IN-GREY 5/8"	109	NA		PANEL ASSY – RH - SLOW
94	417047*	2	BOTTOM PIVOT ASSY	110	NA		PANEL ASSY – RH - FAST
95	411624-1		PILE-NON ADHESIVE BACKED-BROWN	111	717644	2	WASHER-PLAIN 5/8" X 1"
96	714494	2	LABEL – IN EMERGENCY PUSH TO OPEN	<b>OPTIONS</b>			
97	NA		ASSEMBLY – UNIVERSAL THRESHOLD	46b	NA		HANGER, SOLENOID LOCK-FAST PANEL, RH
98	NA		BEVEL EDGE MACHINING – UNIVERSAL THRESHOLD	46c	NA		HANGER, SOLENOID LOCK-FAST PANEL, LH
99	NA		KIT-HARDWARE-UNIVERSAL THRESHOLD	72b	517107-3	1	EXIT INDICATOR - ESCUCHION PLATE, LOCK – CLR
100	410796	8	LABEL - CAUTION AUTO DOOR	72c	537107-3	1	EXIT INDICATOR – ESCUCHION PLATE, LOCK – DK BRZE
101	709480	8	LABEL-CAUTION	80b	417298-1	1	LOCKING BAR GUIDE- CLR-LH FAST
102	417028*	20ft/panel	VINYL-GLAZING CUSTOM	80c	417298-2	1	LOCKING BAR GUIDE-CLR-RH FAST
103a	517211	2	PHOTOBELT-PRO SENSOR AND CABLE	80d	431298-1	1	LOCKING BAR GUIDE-DK BRZ-LH FAST
103b	517211-1	2	PHOTOBELT-PRO SENSOR ONLY	80e	431298-2	1	LOCKING BAR GUIDE-DK BRZ-RH FAST
104	714477	4	WASHER 13/64 ID X ½ OD	81	711463	2	SWITCH – MAGNETIC CONTACT
				112	1000025-1	1	THROW RD ASSY - LH
				113	1000025-2	1	THROW RD ASSY - RH
				114	1000026	2	PANIC BAR (CLEAR)
				115	1400026	2	PANIC BAR (BLACK)
				116	413162	1	EXIT INDICATOR – CLR
				117	433162	1	EXIT INDICATOR – DK BRZE
				118	417337	1	PIN-LOCK EXIT INDICATOR
				119	517107-3	1	ESCUCHION PLATE, LOCK FOR EXIT INDICATOR (CLR)
				120	537107-3	1	ESCUCHION PLATE, LOCK FOR EXIT INDICATOR (BLK)

# Attachment 3 DuraMax™ 5400 Wiring Diagram – MC521 Pro (Sheet 1 of 1)

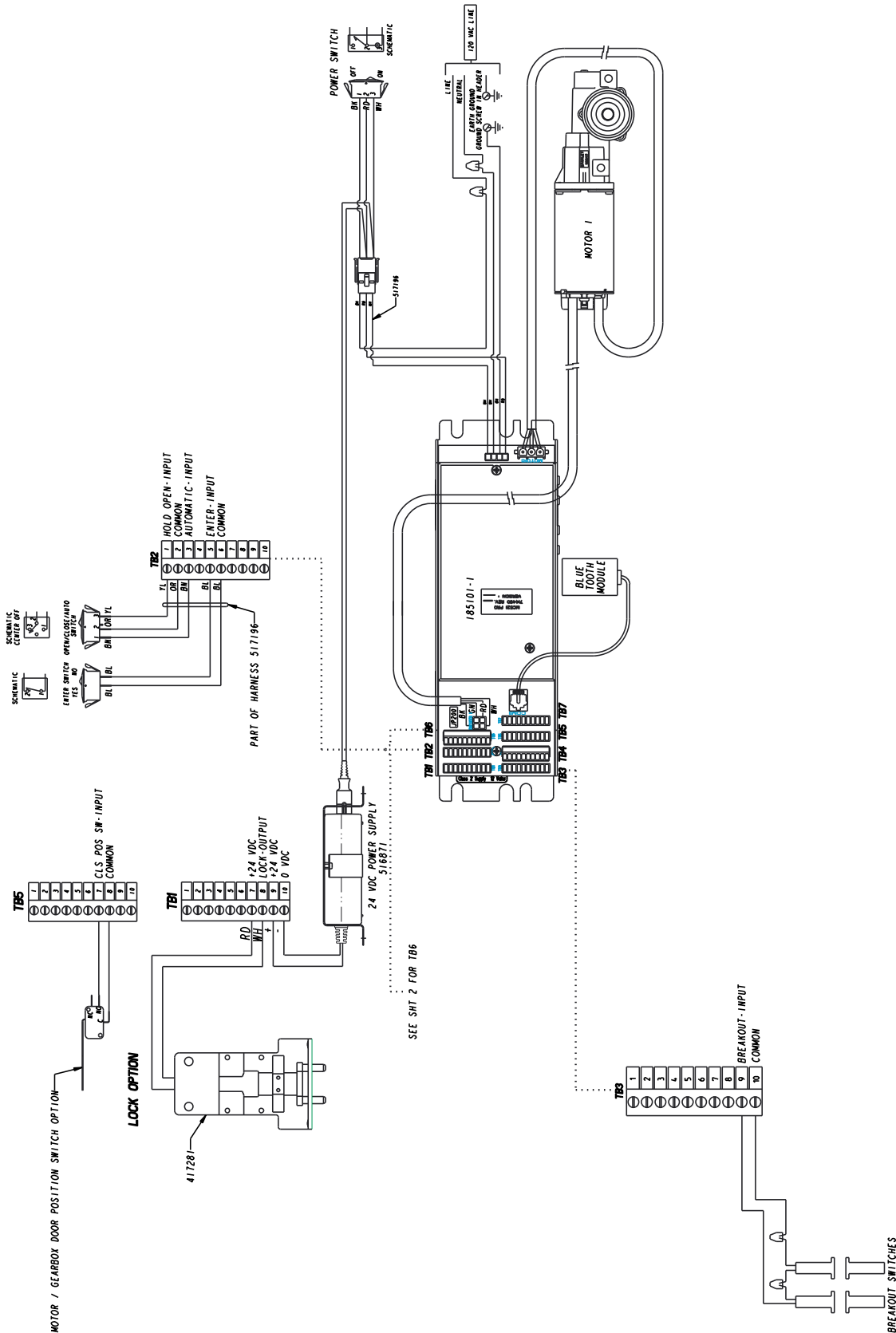

## Attachment 4

(Sheet 1 of 3)

### 4. REPLACING GLASS DOOR PANELS

#### NOTE:

Glazing material in 20ft. segments must be ordered directly from the factory.  
Refer to Attachment 2 for Part No. 417028.

#### TIP:

Reference SO, FAST and SLOW Panel Installation in Sections 3.9, 3.10, and 3.11

#### 4.1 Removing Panels and Glass

4.1.1 REFER to Chart 2 and remove the necessary panels

**Chart 2. Glass Replacement Guide**

Glass Replacement	Panels Removed
SO Panel	Remove SLOW Panel FIRST and FAST Panel SECOND to access the SO Panel
SLOW Panel	Remove SLOW Panel Only
FAST Panel	Remove SLOW Panel FIRST and FAST Panel SECOND

4.1.2 REMOVE the five plugs, and five screws to REMOVE the panel stile. See Figure 18.

**Figure 18. Removing the Panel Stile**

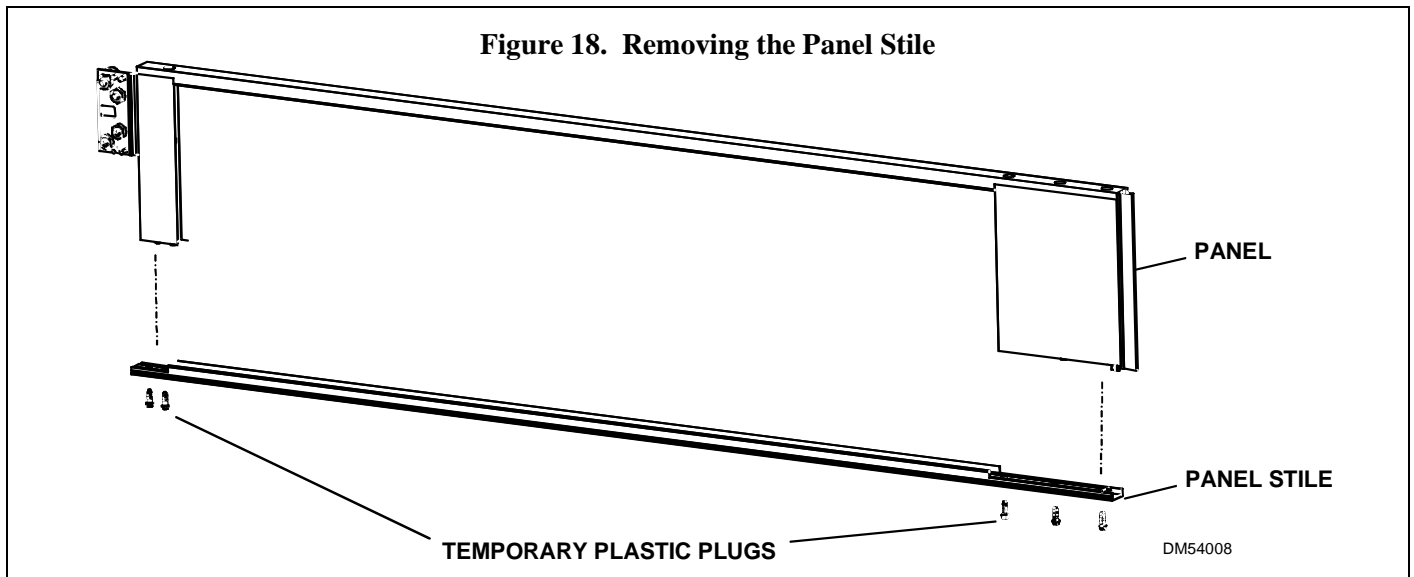

4.1.3 Carefully REMOVE & DISCARD damaged glass and glazing.

## Attachment 4

(Sheet 2 of 3)

### 4.2 Installing Glass into the Panel Assemblies

4.2.1 REMOVE excessive sealant from the perimeter of the thermal glass panels.

4.2.2 Refer to Figure 19, and, using the extruded seal provided, WRAP the perimeter of the thermal glass panel. (Seal may be already factory installed)

**Figure 19. Wrapping the Thermal Glass Panels**

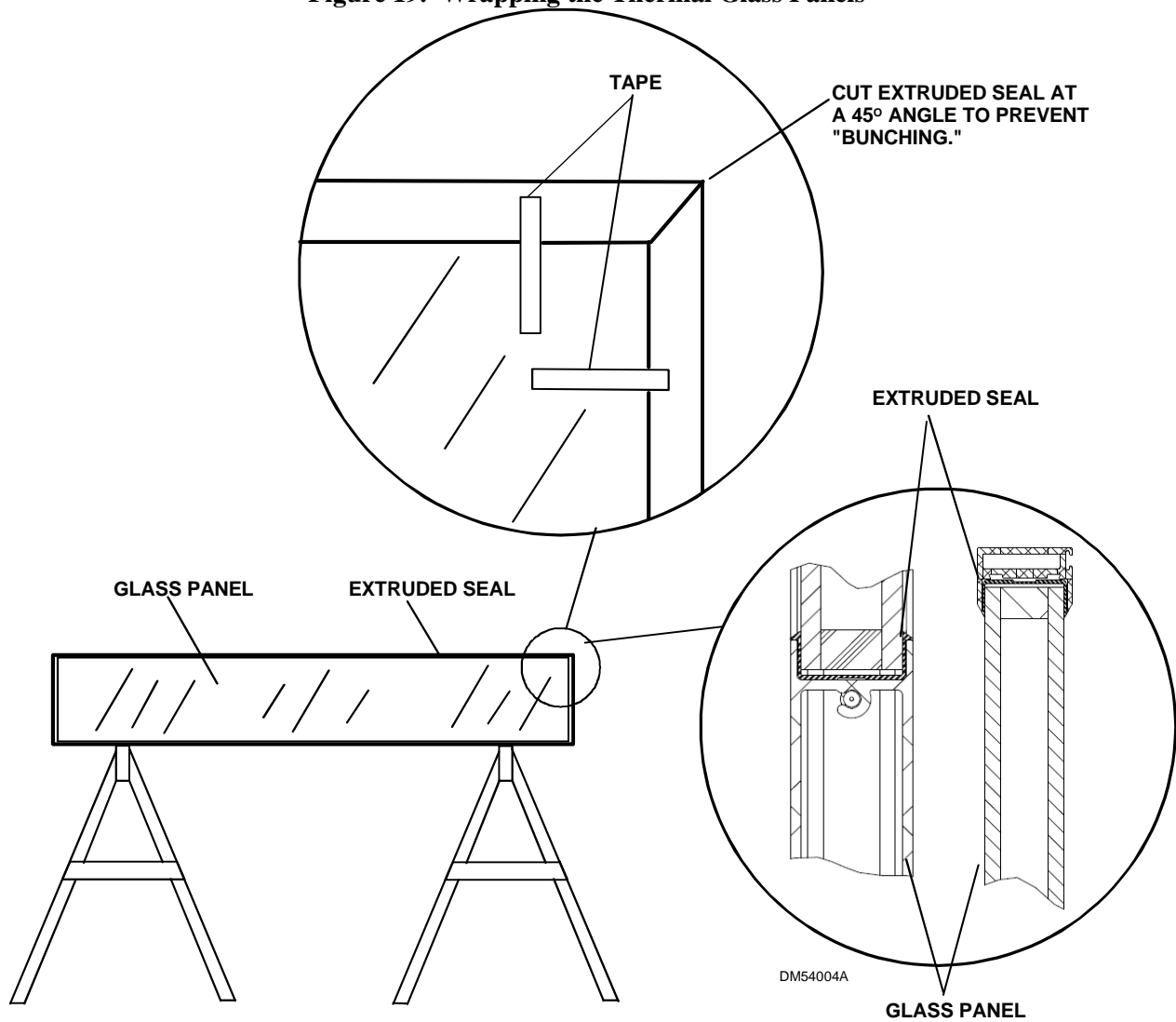

4.2.3 Using tape, SECURE the extruded seal to the thermal glass.

4.2.4 CUT the corners of the seal at a 45-degree angle as necessary to prevent "bunching" and to provide a uniform sealing surface.



## Attachment 4

(Sheet 3 of 3)

4.2.5 Using glass cleaner, COAT the neoprene seal to provide lubrication when inserting the glass into the panel.

4.2.6 Refer to Figure 20, and SLIDE the panel frame onto the glass panel.

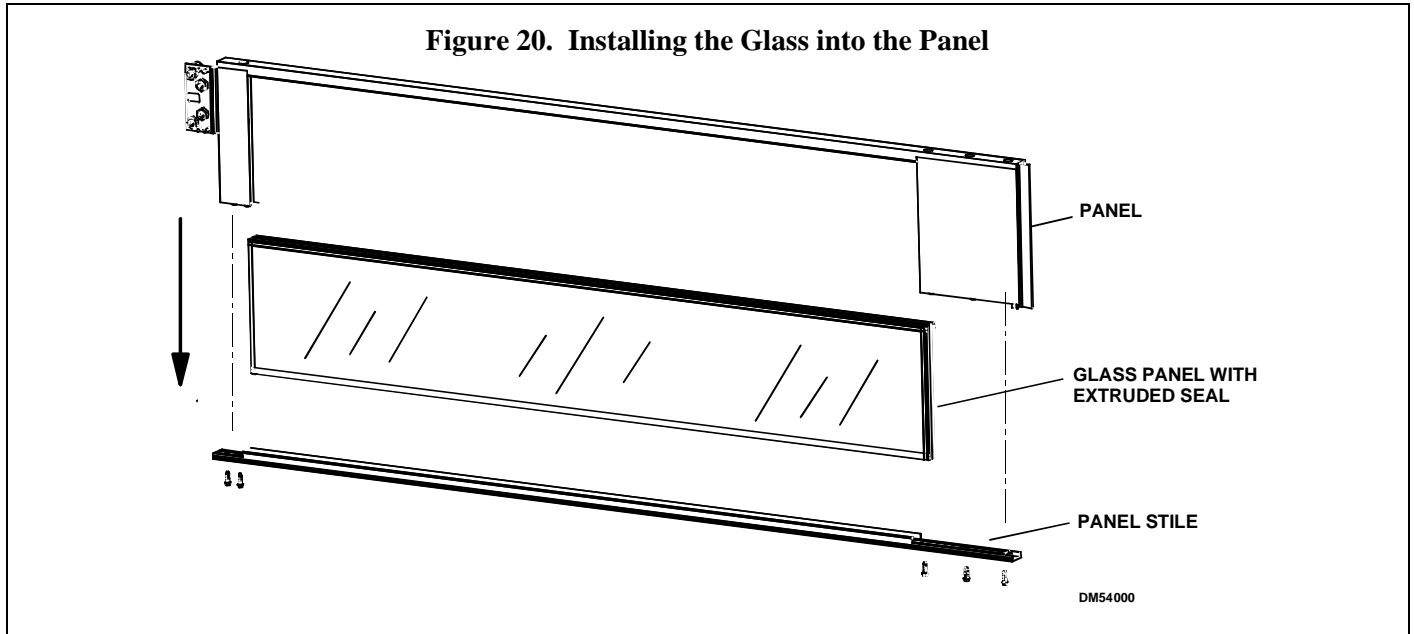

### NOTE:

Start ¼ - 20 x 1" screws by hand to catch existing thread.

If holes are stripped, use 1.5" screws for installation.

4.2.7 Using the ¼-20 x 1" self-threading screws removed in Section 4.1.2, FASTEN the stile to the panel, and ENSURE that the stile is properly mated to the rails and visible gaps are minimal.

4.2.8 Refer to Figure 9, and VERIFY that the hanger rollers on the fast and slow panels have been adjusted to allow easy insertion of the panel into the track assembly. If necessary, ADJUST the hanger rollers.

4.2.9 Refer to sections 3.9, 3.10, and 3.11 and re-install panels as necessary.

## Attachment 5

(Sheet 1 of 1)

### 5. BOTTOM GUIDE INSTALLATION

#### 5.1 Installing the Bottom Guides

##### 5.1.1 Bottom Guides consist of:

- Bottom guides 2L and 2R
- #10 Washers
- #10 Cap Screw x 3/4
- Bushings – 5/16 OD

##### 5.1.2 ASSEMBLE the bottom guide components, and ENSURE the following:

- The SO panel guide faces the *interior* of the building.
- The fast and SX panel guides face the *exterior* of the building.
- Use Loctite® to fasten screws.

##### 5.1.3 ENSURE that the rollers on the guides are at the edge of each panel.

##### 5.1.4 REPEAT steps 5.1.2 and 5.1.3 for opposite side.

**Figure 21. Installing the Bottom Guides**

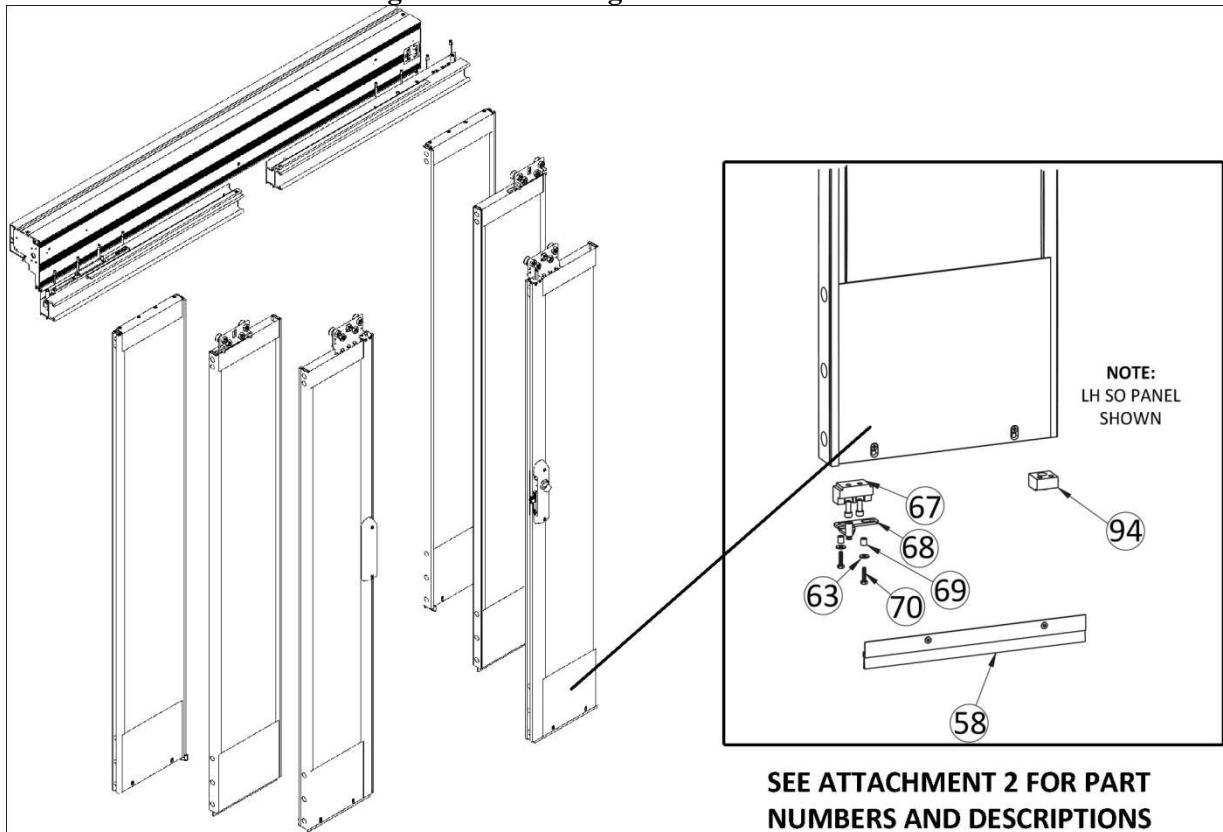

## Attachment 6

### Dura-Max 5400 Option: Installing Solenoid Locking

(Sheet 1 of 2)

#### 6. INSTALLING SOLENOID LOCK OPTION

##### 6.1 Installing the Door Position Switch Bracket (Retrofit Only)

6.1.1 DISCONNECT electrical power from the operator.

6.1.2 Refer to Figure 22, and LOOSEN the bolt securing the motor/gearbox assembly to the header.

6.1.3 SLIDE the switch bracket between the bolt head and the motor/gearbox assembly surface.

6.1.4 TIGHTEN the bolt securing the motor/gearbox assembly to the header, and ENSURE that the bracket tab is flush against the motor/gearbox assembly surface.

##### 6.2 Installing the Switch(es) onto the Bracket (Retrofit Only)

6.2.1 Refer to Figure 23, and, DETERMINE the proper location for the switch(es).

6.2.2 Using the No. 4-40 screws provided, FASTEN the switch(es) to the bracket.

6.2.3 ENSURE that the switches are flush with the belt, but *not* actuated.

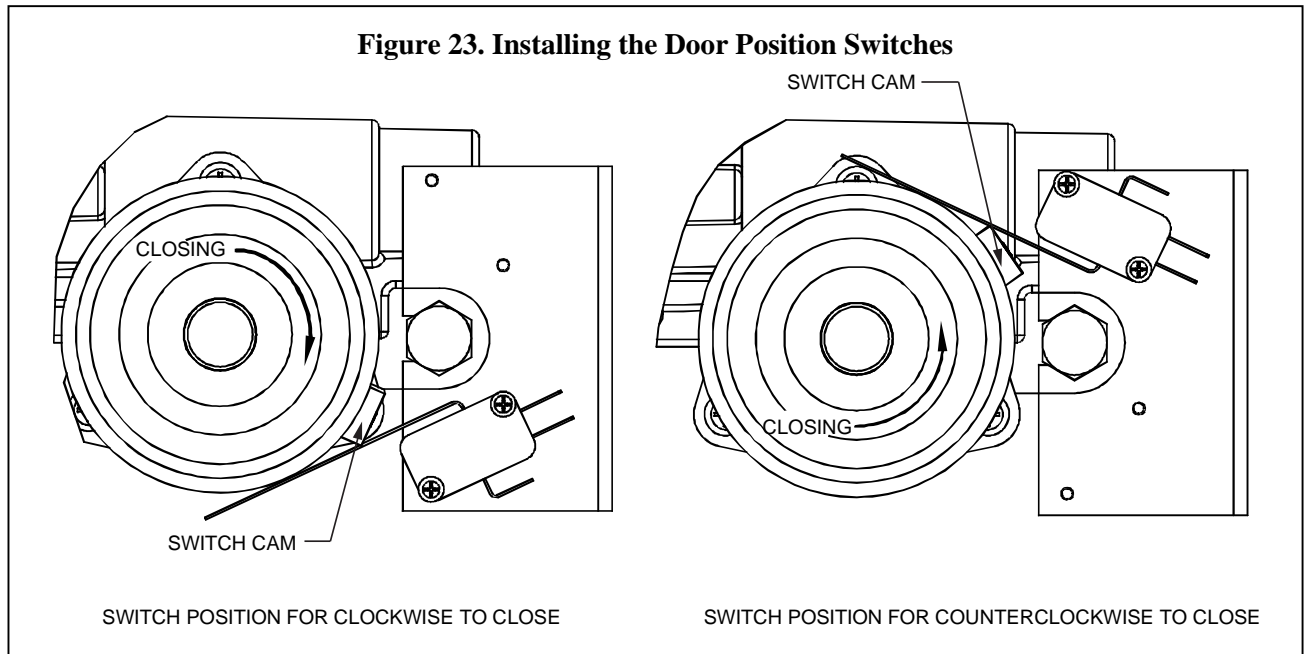
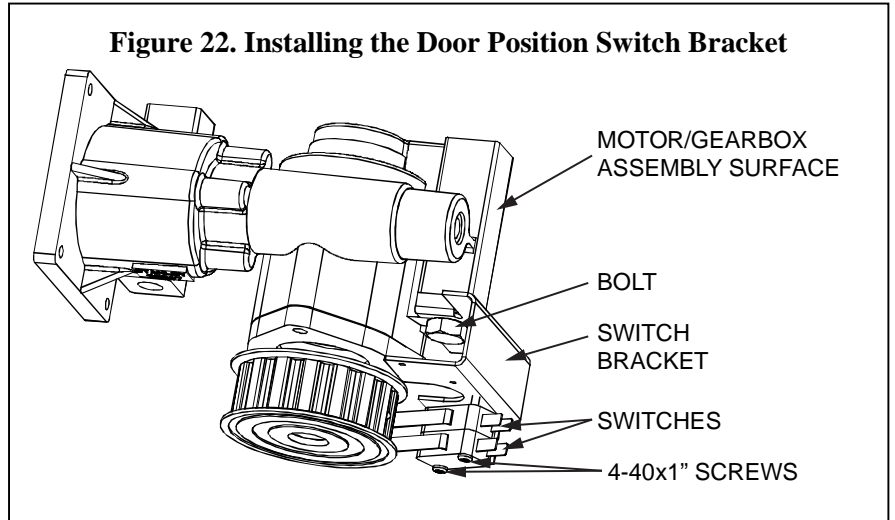

**Attachment 6**  
**Dura-Max 5400 Option: Installing Solenoid Locking**  
(Sheet 2 of 2)

6.3 Installing the Switch Cam on the Timing Belt (New Installation OR Retrofit)

6.3.1 PLACE the door in the fully closed position.

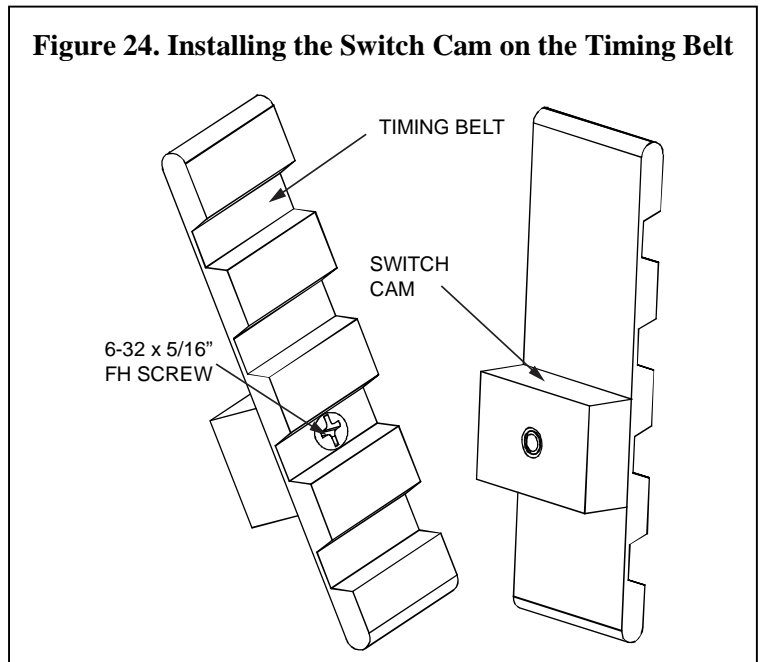

**NOTE**

The switch cam hole in the timing belt must be centered *between* the timing belt teeth. Never locate the switch cam hole on the top of the tooth.

6.3.2 Refer to Figure 24, and MARK the center of the timing belt for the location of the switch cam hole.

6.3.3 DRILL a 1/8" hole through the timing belt at the marked location.

6.3.4 Using the No. 6-32 x 5/16" flat head screw provided, FASTEN the switch cam to the belt.

6.4 Connecting the switch wiring (Retrofit Only)

6.4.1 Refer to Attachment 3, Wiring Diagram

6.5 Configuring the MC521 Pro lock type (New Installation, Retrofit, Replacement)

6.5.1 CONNECT electrical power to the operator

6.5.2 Configure MC521 Pro lock type to Fail Safe or Fail Secure as applicable.

6.6 Close out (New Installation, Retrofit, Replacement)

6.6.1 OPEN and CLOSE the door several times, and ENSURE the following:

- a. The solenoid lock functions properly
- b. Electrical wiring does not interfere with the operation of the lock

**Attachment 7**  
**Dura-Max 5400 Option: Replacing a Solenoid Lock**  
(Sheet 1 of 1)

**7. REPLACING SOLENOID LOCK OPTION**

- 7.1 Refer to Figure 25 and disconnect solenoid lock wires from TB1 location 7 (red) and 8 (white).
- 7.2 REMOVE the two bolts securing the solenoid lock and remove the entire assembly.
- 7.3 Position the new solenoid lock over ball detents and fasten using bolts from 7.2.
- 7.4 CONNECT lock wires to TB1 location 7 (red) and 8 (white).
- 7.5 Repeat Sections 6.5 and 6.6.

**Figure 25. Replacing Solenoid Lock Option**

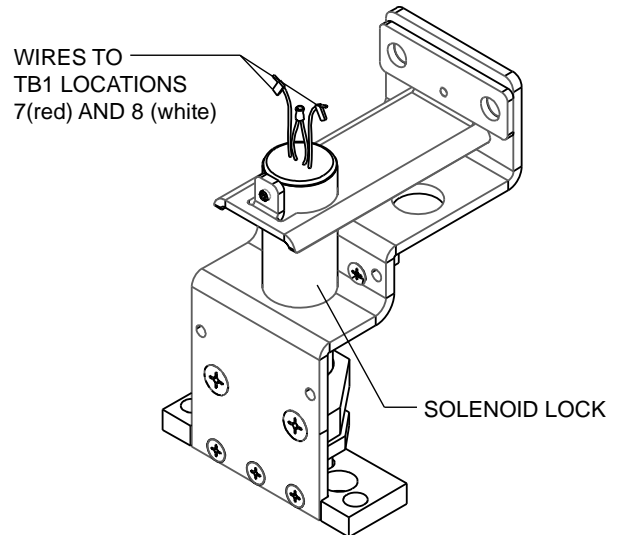

## Attachment 8

### Dura-Max 5400 Option: Installing a Panic bar with Access Control

(Sheet 1 of 5)

#### 8. INSTALLING PANIC BAR FOR ACCESS CONTROL OPTION

- 8.1 PLACE both SX fast panels on a flat surface or saw horses.
- 8.2 LOCATE the panic bar, #10-32 x 3/4" screws and #8 x 1/2" self drilling screws.
- 8.3 REMOVE the cover from the panic bar by removing one end cap and sliding off. Refer to Figure 26.
- 8.4 REMOVE the end cap from the panic bar base next to the panic bar cam.

**Figure 26. Removing Panic Bar Cover**

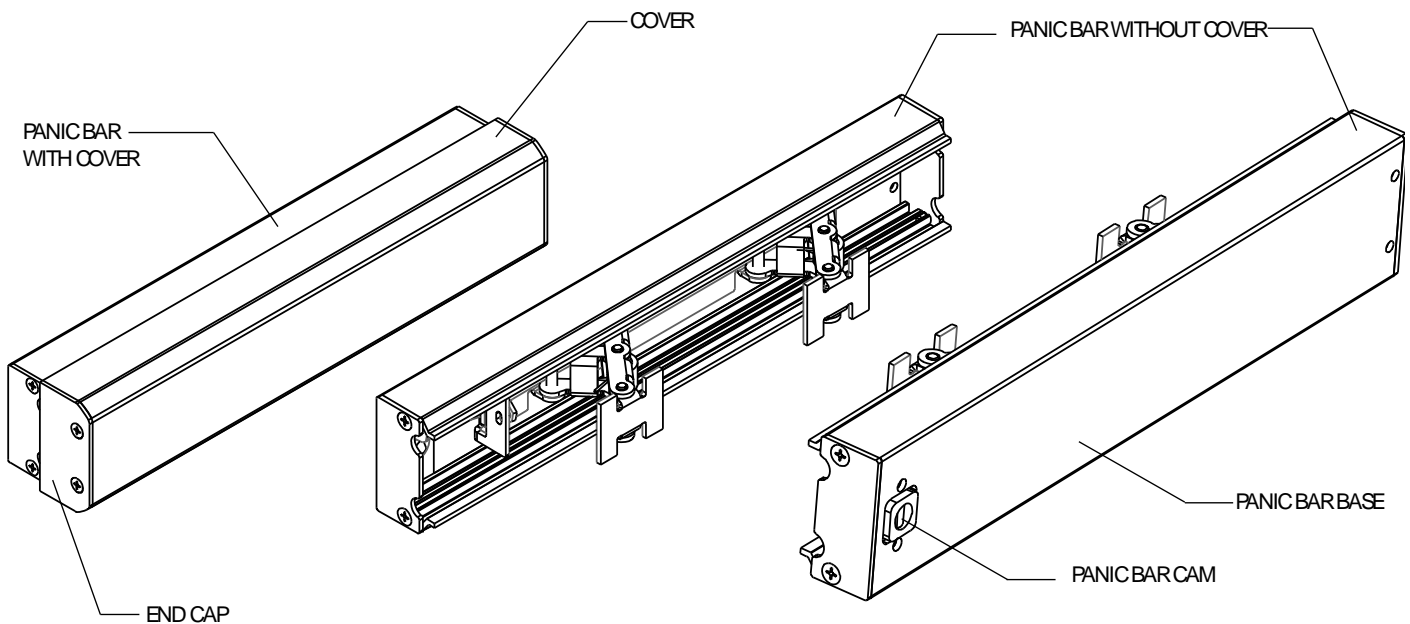

**Attachment 8**  
**Dura-Max 5400 Option: Installing a Panic bar with Access Control**  
(Sheet 2 of 5)

8.5 PLACE the Panic Bar onto the panel aligning the panic bar cam with the throw rod cam as shown in Figure 27 and Figure 28

**Figure 27. Installing the panic Bar**

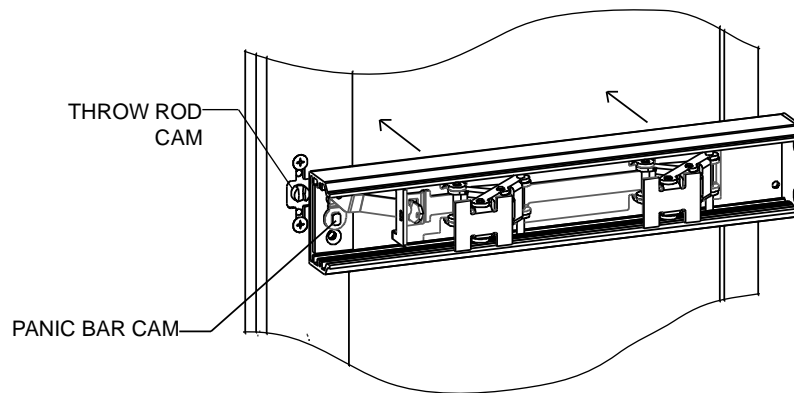
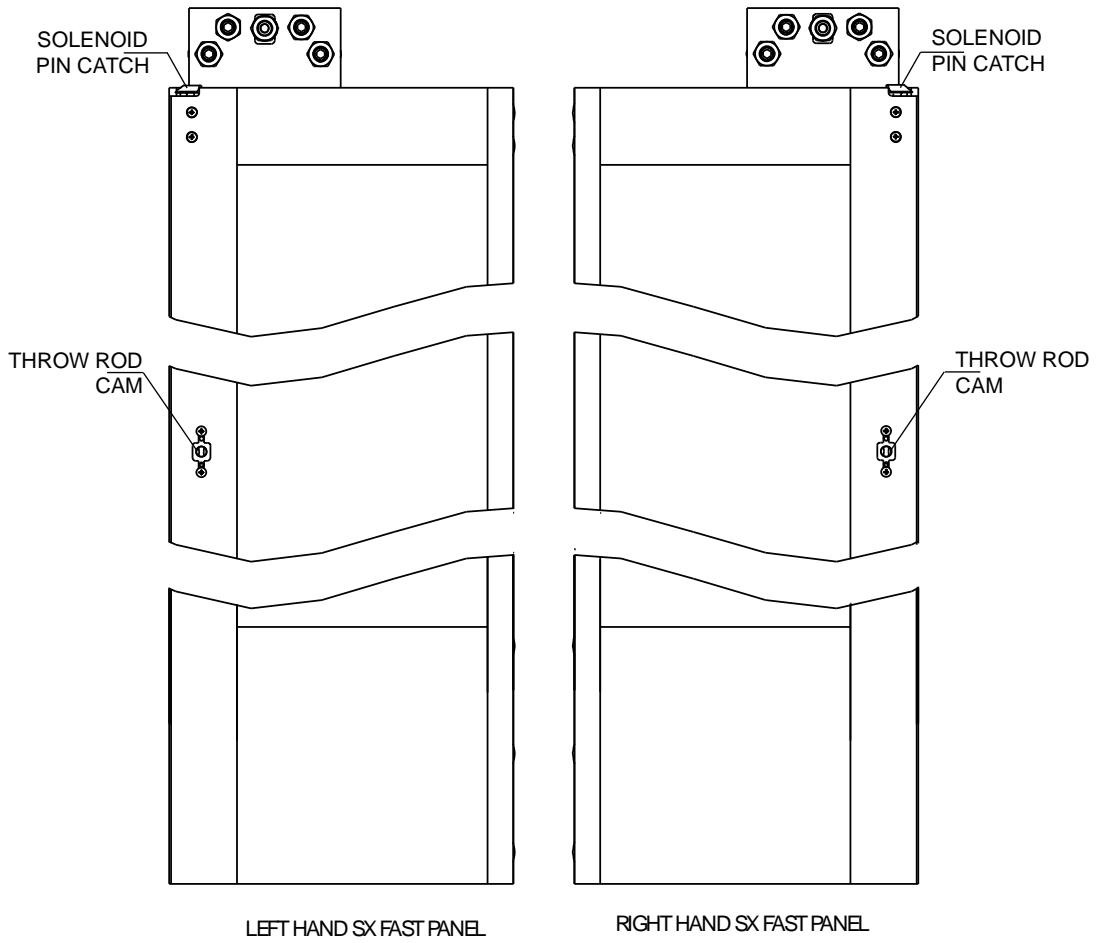

**Attachment 8**  
**Dura-Max 5400 Option: Installing a Panic bar with Access Control**  
(Sheet 3 of 5)

- 8.6 ALIGN the panic bar cam as shown in Figure 28. The cam block can be rotated and aligned in the proper direction easily, so it is handed correctly.
- 8.7 INSTALL #10-32 x 3/4" screws on LEFT SX FAST PANEL (See Figure 28)
- 8.7.1 DEPRESS the panic mechanism to reveal the hidden screw hole and install screw as shown. The screw may need to be inserted in the hole before the cam block is oriented and seated. Do not tighten completely.
- 8.7.2 INSTALL the #10-32 x 3/4" screw into the open hole next to the panic bar cam. Do not tighten completely.
- 8.8 INSTALL #10-32 x 3/4" screws on RIGHT SX FAST PANEL (See Figure 28)
- 8.8.1 INSTALL the #10-32 x 3/4" screw into the open hole next to the panic bar cam. Do not tighten completely.
- 8.8.2 DEPRESS the panic mechanism to reveal the hidden screw hole and install screw. Do not tighten completely.

**Figure 28. Installing the panic Bar**

LEFT HAND SX FAST PANEL

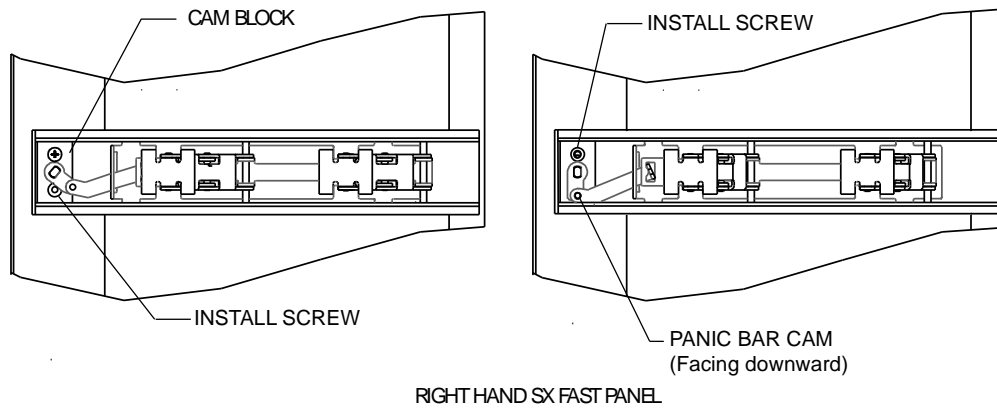

RIGHT HAND SX FAST PANEL

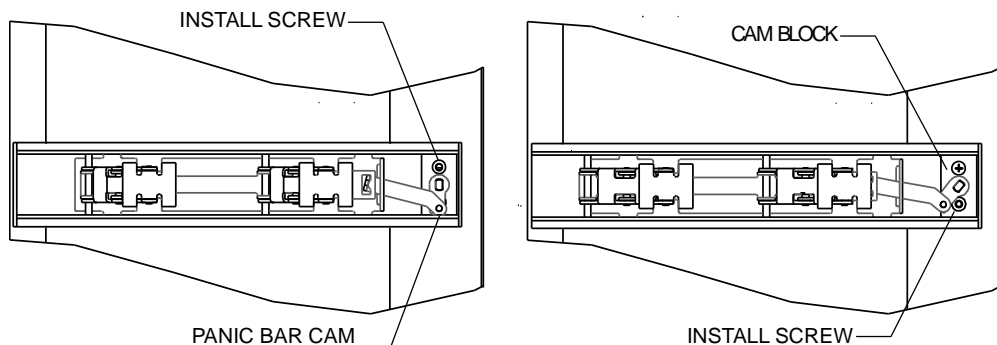



**Attachment 8**  
**Dura-Max 5400 Option: Installing a Panic bar with Access Control**  
(Sheet 4 of 5)

**CAUTION**

When drilling the mounting holes for the Panic bar, note that the glass is inside the stile pocket.  
Holes can only be drilled 3/8" max from the edge of the stile.

8.9 The following steps apply for both SX Fast Panels.

- 8.10 SQUARE UP Panic Bar in relation to door. The panic bar should be parallel to both the top and bottom rail.
- 8.11 DRILL two 3/32" pilot holes through the panic bar base and into the stile 3/16" from the end of the panic bar base, but not more than 3/8" from the edge of the stile as shown in Figure 29.
- 8.12 INSTALL two # 8 x 1/2" self drilling screws into the previously drilled holes.
- 8.13 TIGHTEN the two #10-32 x 3/4" screws next to the Panic Bar Cam that were previously installed.

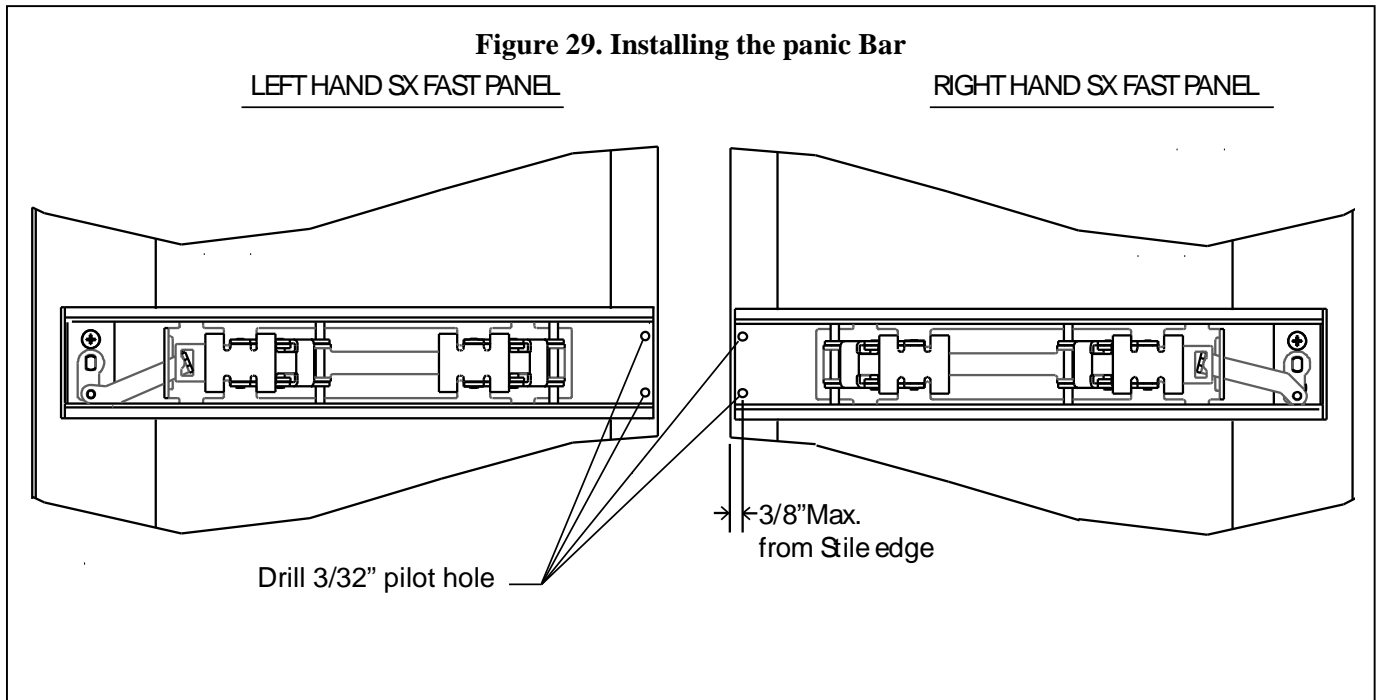

**Attachment 8**  
**Dura-Max 5400 Option: Installing a Panic bar with Access Control**  
(Sheet 5 of 5)

- 8.14 SLIDE the cover onto the plates of Panic Bar mechanism as shown in Figure 30. Both plates need to slide into the slot on the panic bar cover.
- 8.15 INSTALL the end caps on the Panic Bar cover and base.

**Figure 30. Installing the panic Bar**

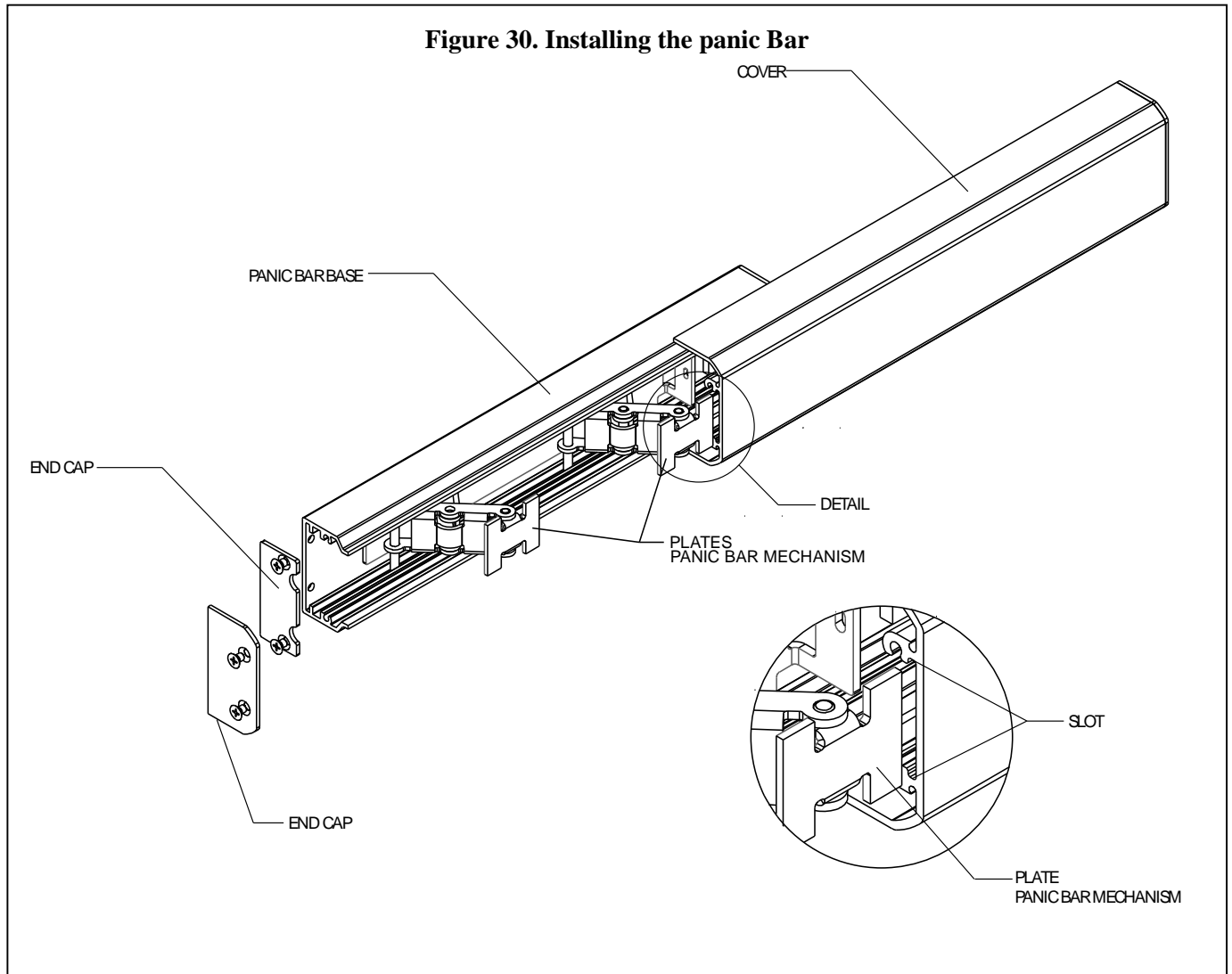

**Attachment 9**  
**Dura-Max 5400 Option: Adjusting the Solenoid Lock**  
(Sheet 1 of 2)

9. ADJUSTING THE SOLENOID LOCK

- 9.1 LOOSEN the set screw at the top of the solenoid lock as shown in Figure 31.
- 9.2 LOOSEN the set screws at the bottom of the solenoid lock on the back side. See Figure 31.
- 9.3 With the pins in the lowered position raise or lower the solenoid so the SCORED LINE on the pins is aligned to the top of the pin catches. This will achieve a  $\frac{1}{4}$ " of engagement of the pins into the pin catches. See Figure 32.
- 9.4 TIGHTEN screws that were previously loosened in step 9.1 and 9.2.
- 9.5 ENSURE the both left hand and right hand panels are adjusted in the same manner.

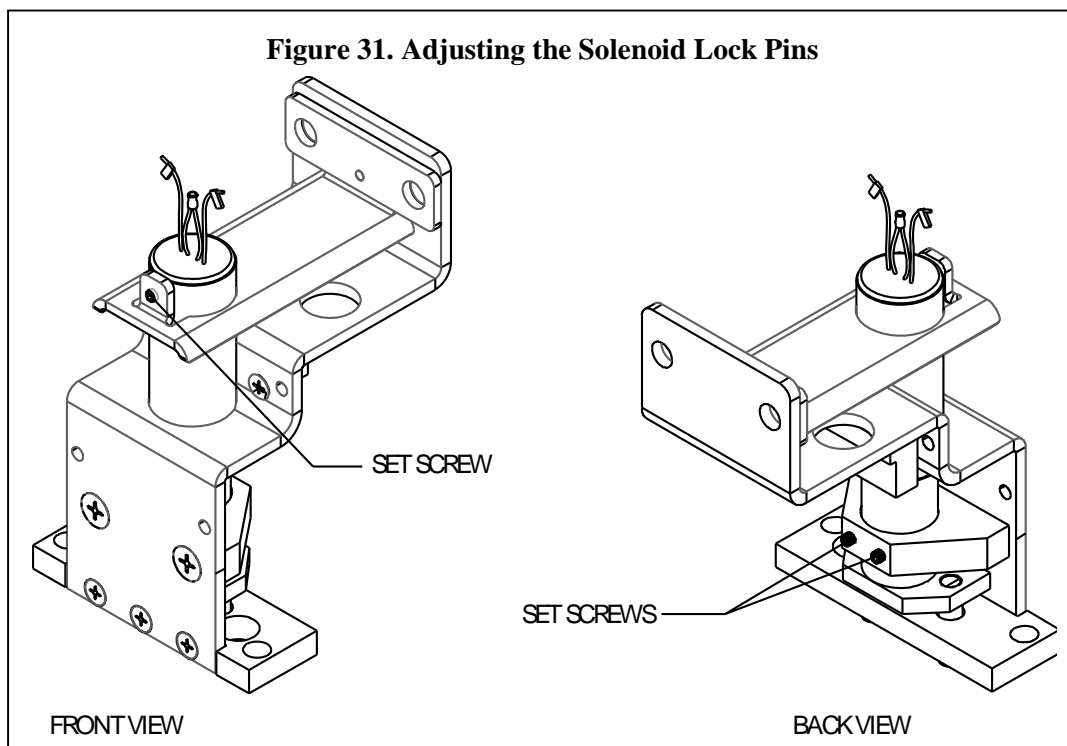

Attachment 9  
Dura-Max 5400 Option: Adjusting the Solenoid Lock  
(Sheet 2 of 2)

Figure 32. Adjusting the Solenoid Lock Pins

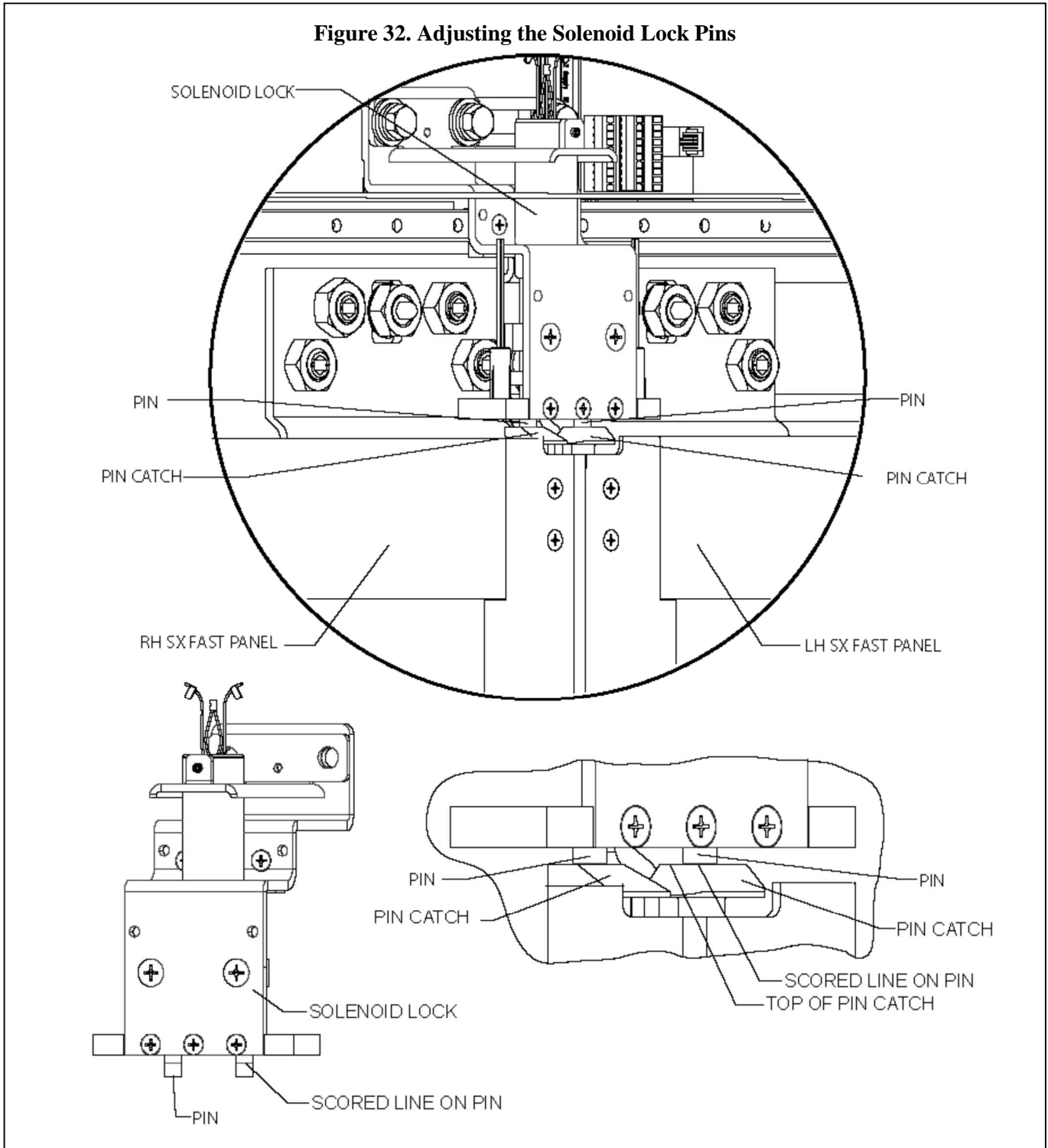

**Attachment 10**  
**Dura-Max 5400 Option: Adjusting the Pin catch for Access Control**  
(Sheet 1 of 1)

9.6 IF both pins do not have a ¼” of engagement then complete the following:

9.6.1 RAISE OR LOWER the door panel. See section 3.12

OR

9.6.2 ADJUST the pin catch height.

- a. REMOVE the hole plugs shown in Figure 33.
- b. REMOVE the screws shown in Figure 33.
- c. HOLD the throw rod with a pair of pliers through the plug holes.
- d. TURN the pin catch counter clock wise keeping in mind that the bracket will spin with it, but the throw rod should not spin. This will open a gap between the bottom of the pin catch and the throw rod and therefore raise the pin catch height.

9.6.3 REINSTALL the screws into the pin catch bracket.

9.6.4 CHECK alignment.

9.6.5 REINSTALL the hole plugs.

